

FRONT VIEW

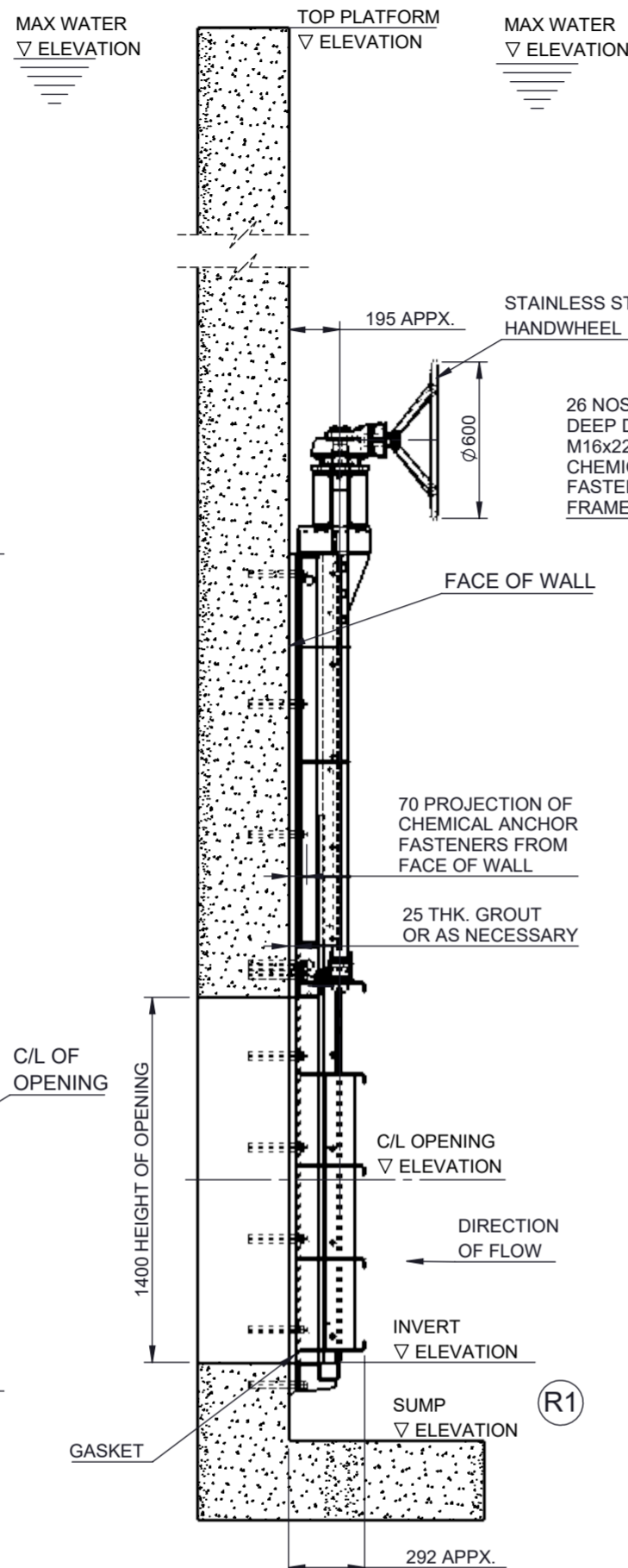

SIDE VIEW WITH CUT SECTION OF WALL

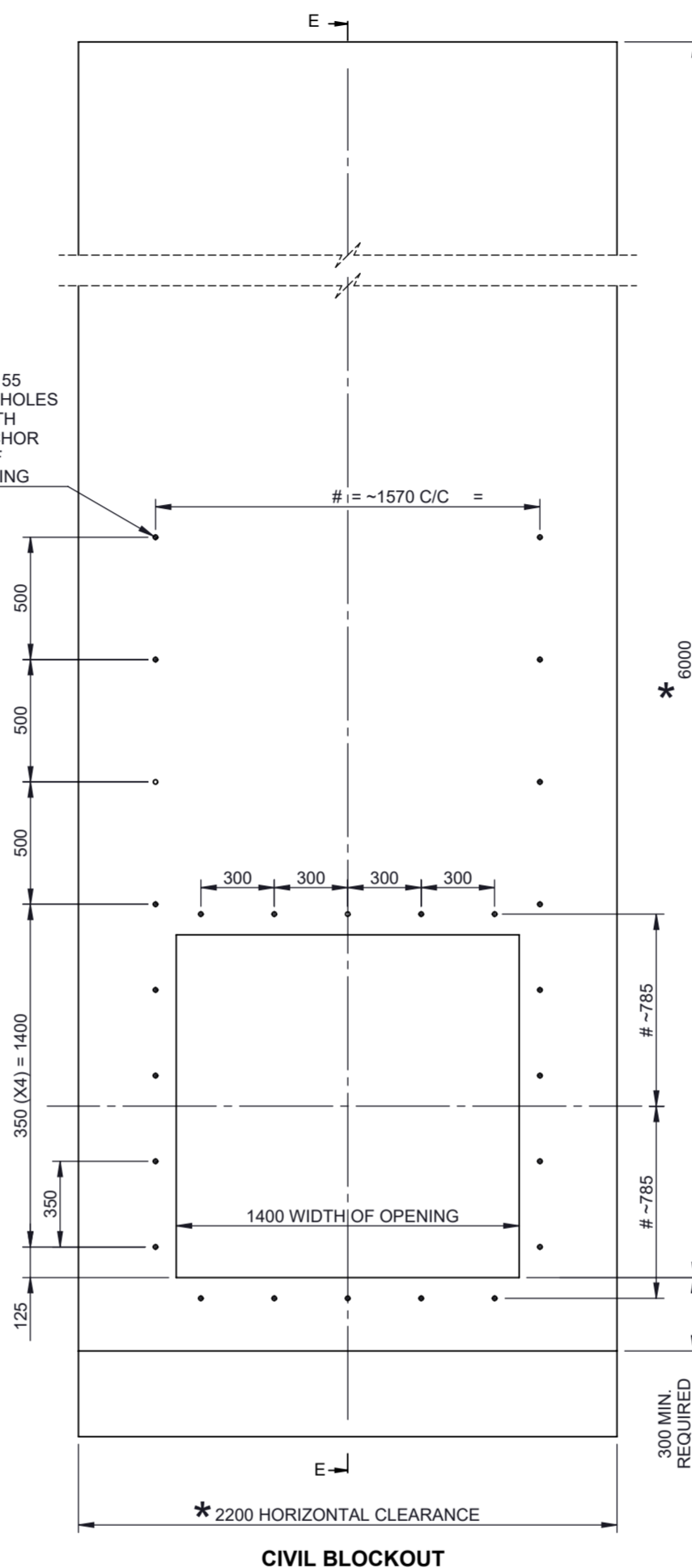

CIVIL BLOCKOUT

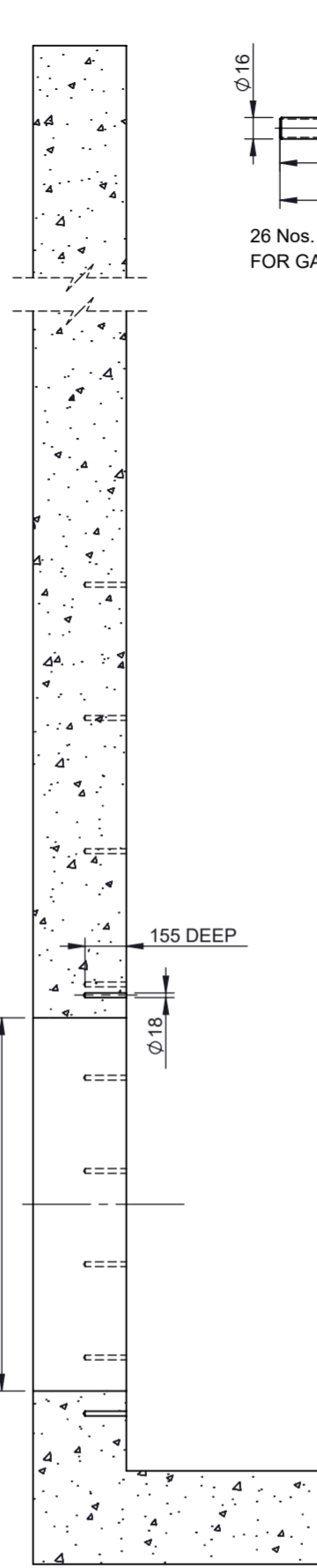

SECTION E-E

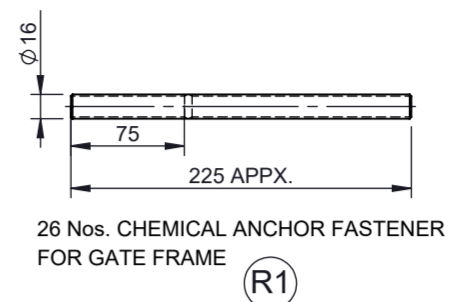

26 Nos. CHEMICAL ANCHOR FASTENER FOR GATE FRAME (R1)

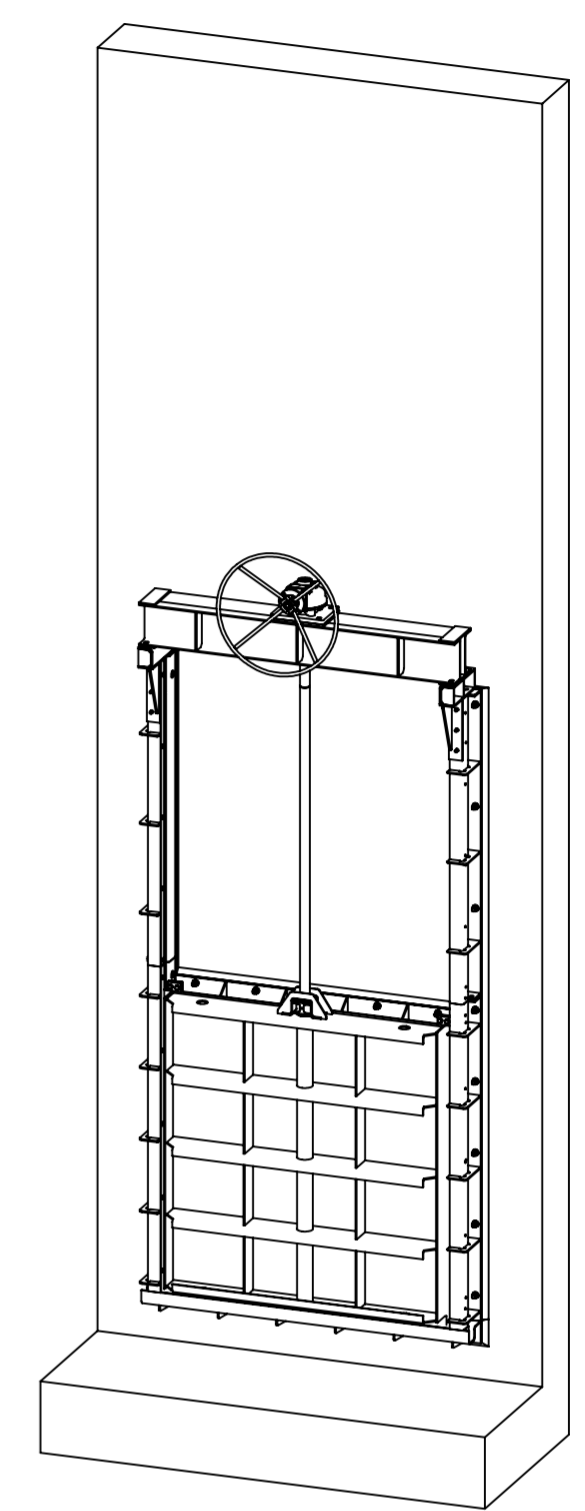

ISOMETRIC VIEW

S.NO.	DESCRIPTION	MATERIAL
10	GEAR BOX IB5 (4:1) F10A (MAKE ROTORK)	
9	YOKE	STAINLESS STEEL BS EN 10088-2 Gr-1.4401 TYPE 316
8	BOTTOM SEAL	EPDM ASTM D2000
7	TOP SEAL	UHMWPE (BACKED WITH EPDM ASTM D2000)
6	SIDE SEAL	
5	THRUST NUT	GUNMETAL BS EN 1982 LG-2
4	STEM	STAINLESS STEEL BS EN 10088-3 Gr-1.4401 TYPE 316
3	SHUTTER	STAINLESS STEEL BS EN 10088-2 Gr-1.4401 TYPE 316
2	FRAME	
1	TRANSIT STOP	HDPE

- NOTE:-
- ALLOWABLE DEVIATION FOR DIMENSIONS WITHOUT SPECIFIED TOLERANCES TO BE AS PER ISO:2768.
 - I - ALL FASTENERS (NUTS,BOLTS & WASHERS) FOR GATE ASSEMBLY & OPERATOR ASSEMBLY TO BE OF STAINLESS STEEL ASTM TYPE 316.
 - II - ALL CHEMICAL ANCHOR FASTENERS (NUTS,BOLTS & WASHERS) FOR GATE FRAME TO BE OF STAINLESS STEEL ASTM TYPE 316
 - ALL STAINLESS STEEL FABRICATED PARTS TO BE BLAST CLEANED TO REMOVE SURFACE CONTAMINATION AND THEREAFTER PICKLED AND PASSIVATED.
 - CONTRACTOR TO CONFORM DIMENSION IN *

- TRANSIT STOPS (PAINTED IN RED) SHOULD NOT BE REMOVED UNTIL THE GATE IS INSTALLED AND IS TO BE INITIALLY OPERATED.
- ADHESIVE CAPSULE/CHEMICAL CAPSULE FOR CHEMICAL ANCHOR FASTENERS TO BE ARRANGED BY WATERFRONT FLUID CONTROLS..
- APPROX. WEIGHT OF GATE ASSEMBLY IS 550 kg.
- THE GATE IS PROVIDED WITH CONVENTIONAL BOTTOM CLOSURE, WALL MOUNTED, SELF CONTAINED & NON-RISING STEM.
- ANCHOR BOLT HOLE LOCATION ON CIVIL WALL TO BE MARKED BY TAKING REFERENCE FROM GATE FRAME.
- THIS PROPOSAL DRAWING IS SUBJECT TO CHANGE UPON CARRYING OUT DETAILED ENGINEERING AFTER RECEIPT OF ORDER. HENCE DESIGN, DIMENSION AND MATERIAL OF CONSTRUCTION MAY SLIGHTLY VARY AFTER CARRYING OUT DETAILED ENGINEERING.
- FOR SECTIONAL DETAILS SEE DRG NO. GA-A-QTN-4823004-A

1	DESIGN HEAD	+6.0M
2	OPENING WIDTH	1400mm
3	OPENING HEIGHT	1400mm
4	IL TO PL	6.0m
5	OPERATING ARRANGEMENT	MANUAL
6	DESIGN STANDARD	BS7775

WATERFRONT FLUID CONTROLS



S.NO.	DATE	DESCRIPTION	REV.BY	APPROVAL
R1	05.03.20	CBC WAS FBC GATE CHANGED.	S.S.V.	N.K.V.

DRAWN BY: SSV	PROJECT: ----	GENERAL TOLERANCES: ±0.2mm	FIRST ANGLE PROJECTION	DO NOT SCALE FROM THIS DRAWING
CHECKED BY: DD	LOCATION: ----	MACHINING: <1000mm ±1.5mm		
APPROVED BY: N.K.V.	TAG NO.: ----	DIMS: >1000mm ±2.0mm		
	QTY.: 01 NO.			
	DATE :- 27.02.20			

THIS DOCUMENT IS COPYRIGHT AND IS THE PROPERTY OF WATERFRONT FLUID CONTROLS. IT MUST NOT BE COPIED OR DISCLOSED TO A THIRD PARTY, INCLUDING MANUFACTURE OF THE PRODUCT SHOWN THEREIN, WITHOUT THE WRITTEN CONSENT OF THE COMPANY.

2009 WATERFRONT FLUID CONTROLS

TITLE:- GENERAL ARRANGEMENT & CIVIL BLOCK OUT FOR NON-RISING STEM STAINLESS STEEL SLUICE GATE DETAILS FOR A-113 SIZE - 1400(W) X 1400(H)mm.

MATERIAL: SEE MATERIAL NOTES

DRAWING NUMBER: GA-A-QTN-4823004

REV NUMBER: R1

SHEET NUMBER 1 OF 2

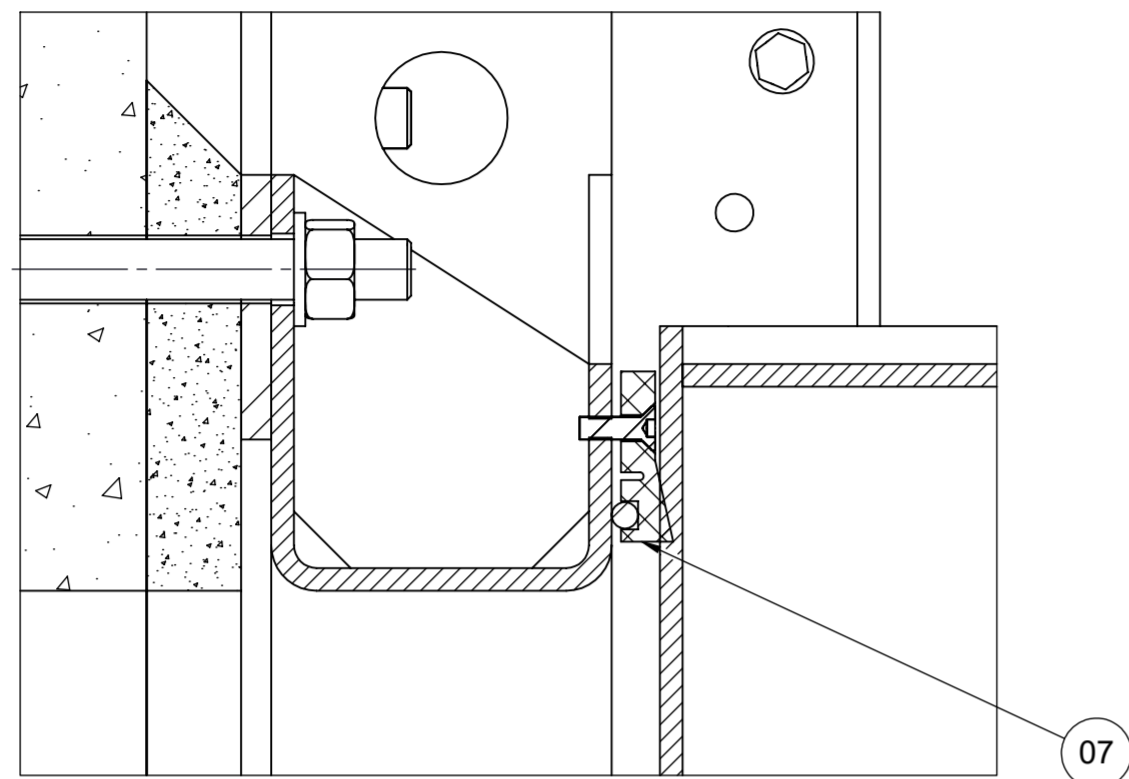

TOP SEALING SECTION

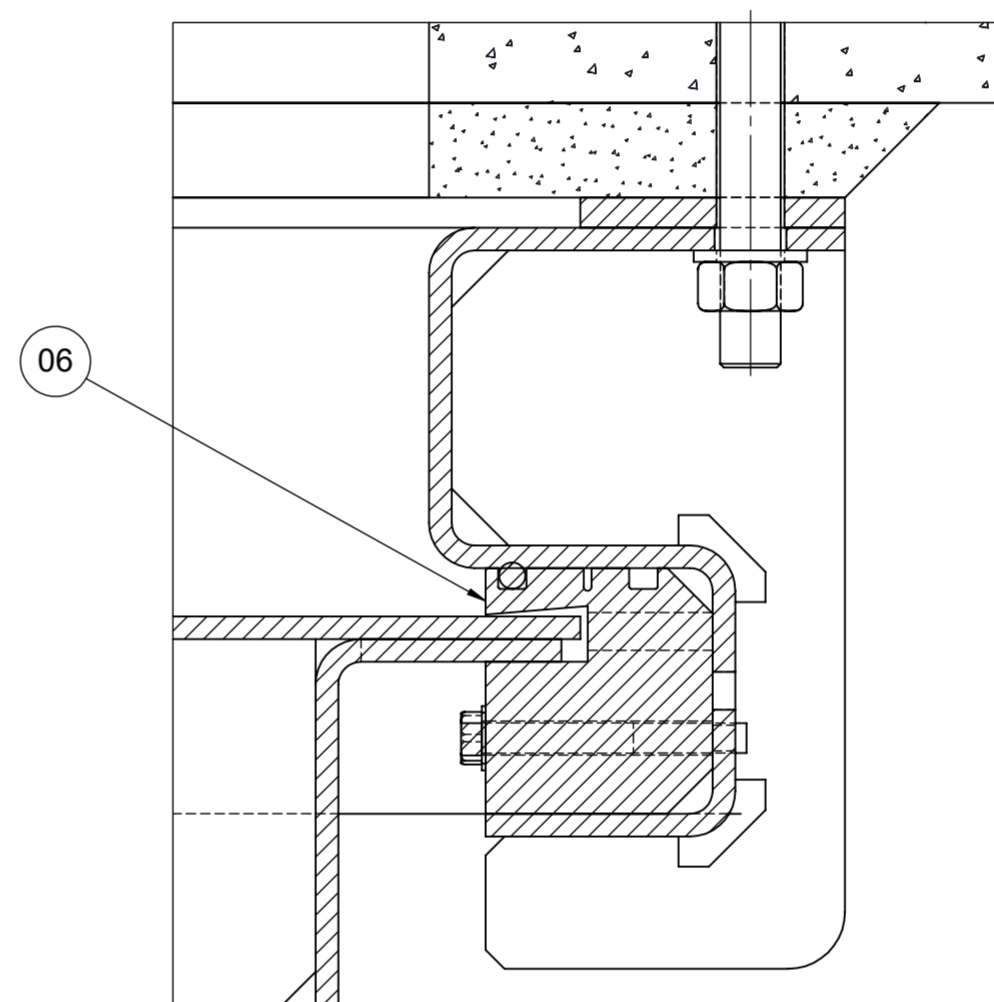

SIDE SEALING SECTION

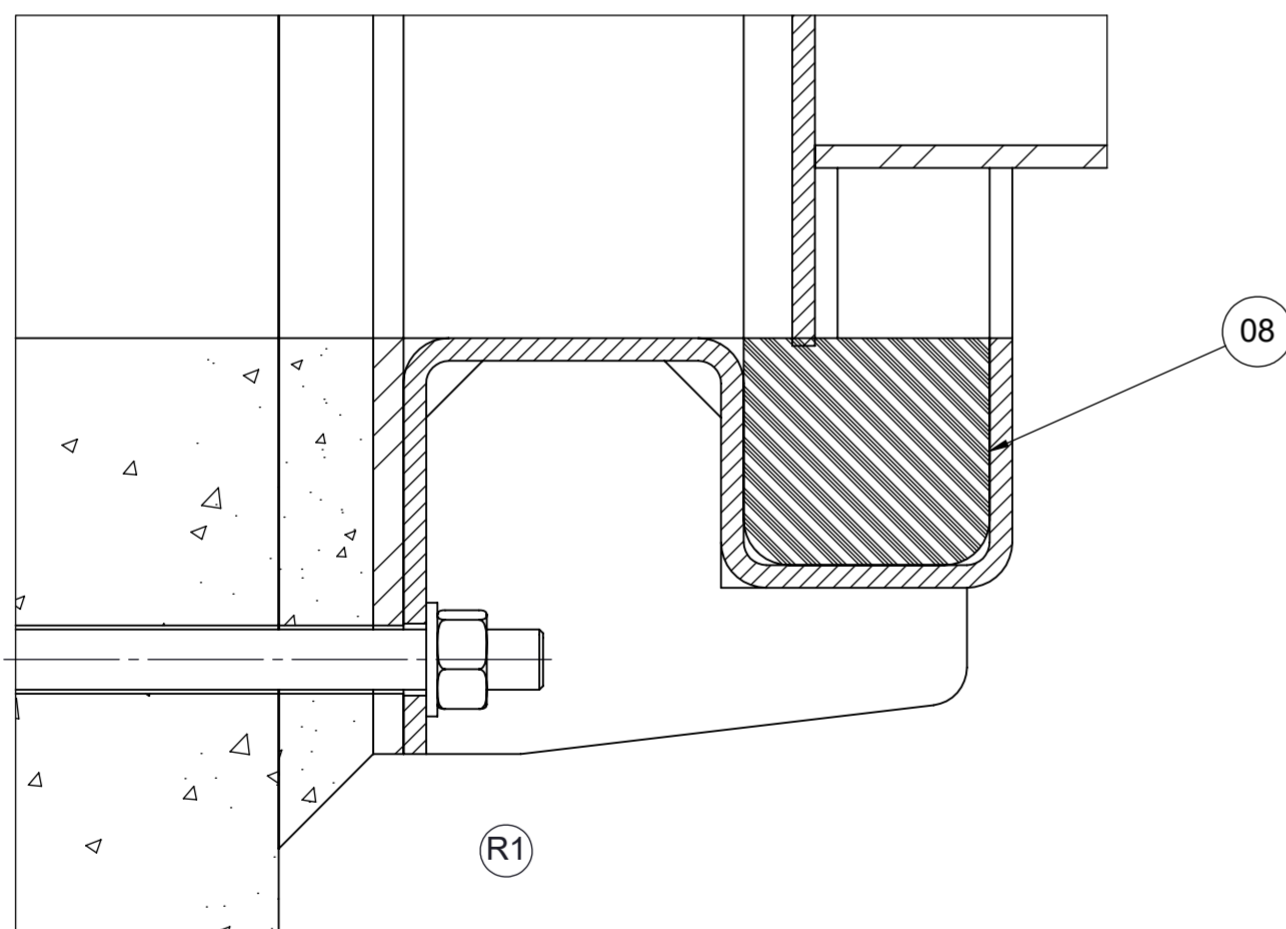

BOTTOM SEALING SECTION

NOTE:-
1. FOR GENERAL ARRANGEMENT SEE DRG NO. GA-A-QTN-4823004

WATERFRONT FLUID CONTROLS



S.NO.	DATE	DESCRIPTION	REV.BY	APPROVAL
R1	05.03.20	CBC WAS FBC GATE CHANGED.	S.S.V.	N.K.V.

DRAWN BY: SSV	PROJECT:
CHECKED BY: DD	LOCATION:
APPROVED BY: N.K.V.	TAG NO. :
	QTY. : 01 NO.

GENERAL TOLERANCES: MACHINING: ±0.2mm DIMS: <1000mm ±1.5mm DIMS: >1000mm ±2.0mm	FIRST ANGLE PROJECTION	DO NOT SCALE FROM THIS DRAWING
THIS DOCUMENT IS COPYRIGHT AND IS THE PROPERTY OF WATERFRONT FLUID CONTROLS. IT MUST NOT BE COPIED OR DISCLOSED TO A THIRD PARTY, INCLUDING MANUFACTURE OF THE PRODUCT SHOWN THEREIN, WITHOUT THE WRITTEN CONSENT OF THE COMPANY.		
2009 WATERFRONT FLUID CONTROLS		

TITLE:- SECTION DETAILS FOR NON-RISING STEM STAINLESS STEEL FACE WALL MOUNTED SLUICE GATE. A-113 SIZE - 1400(W) X 1400(H)mm.
MATERIAL: SEE MATERIAL NOTES

DRAWING NUMBER: GA-A-QTN-4823004-A
REV NUMBER: R1
SHEET NUMBER 2 OF 2