

ALL DIMENSIONS IN MM UNLESS OTHERWISE STATED DO NOT SCALE - IF IN DOUBT ASK

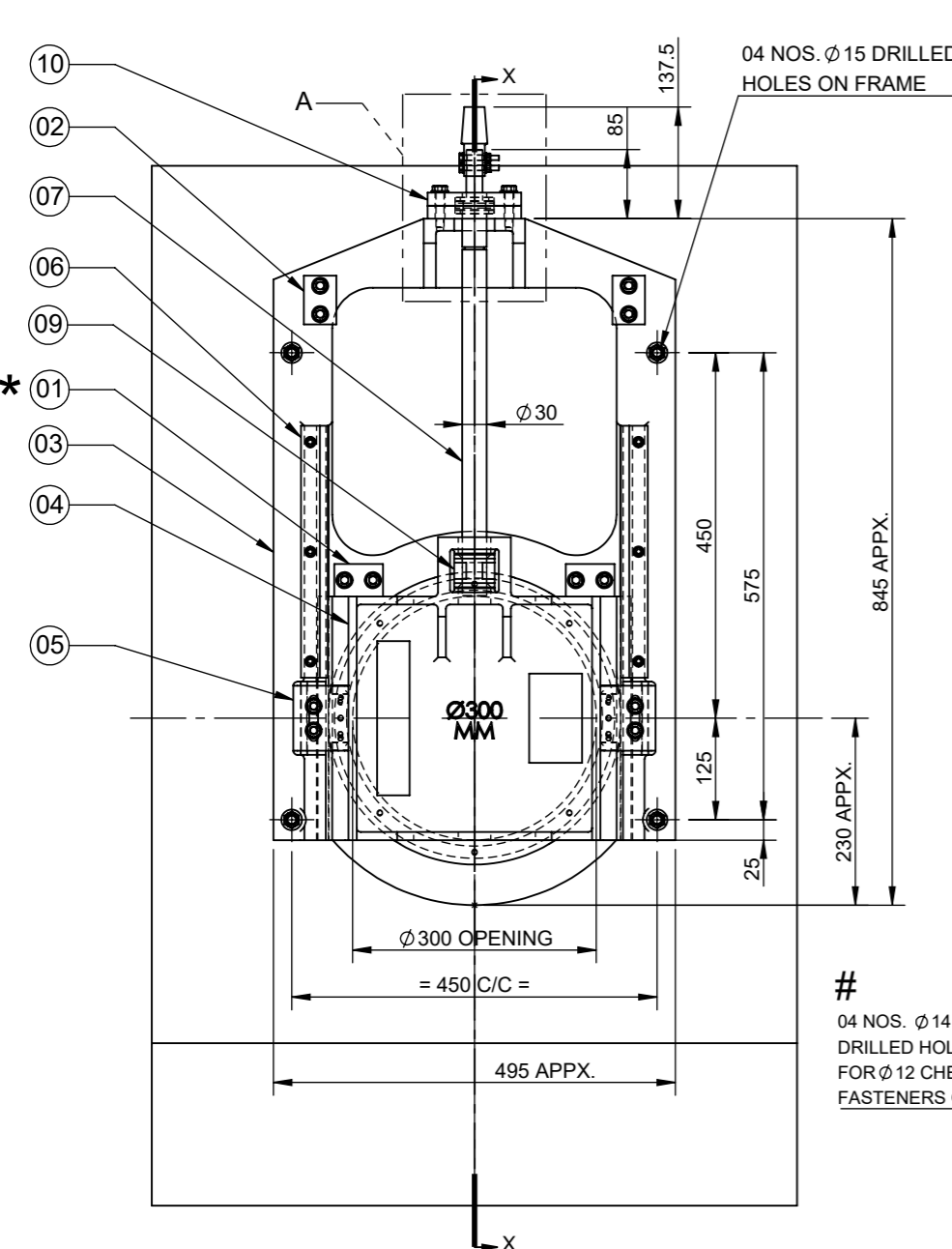

FRONT VIEW OF CAST IRON SLUICE GATE

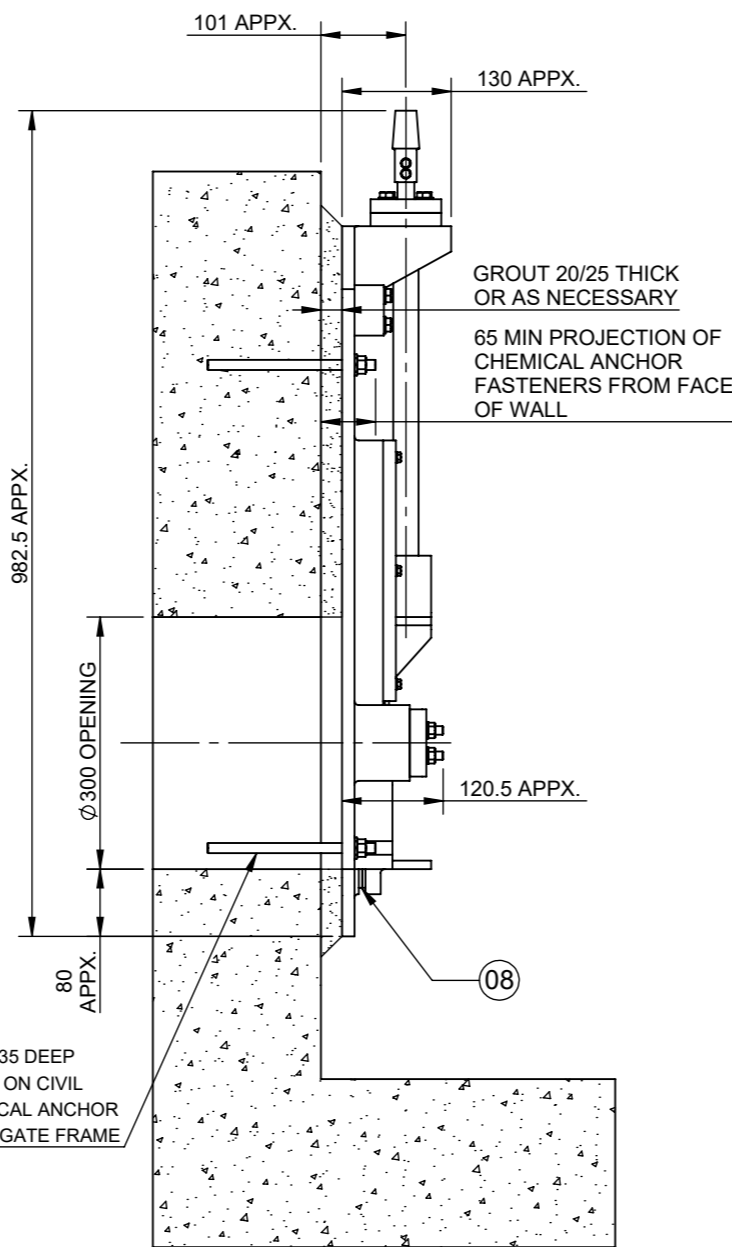

SIDE VIEW WITH CUT SECTION OF WALL

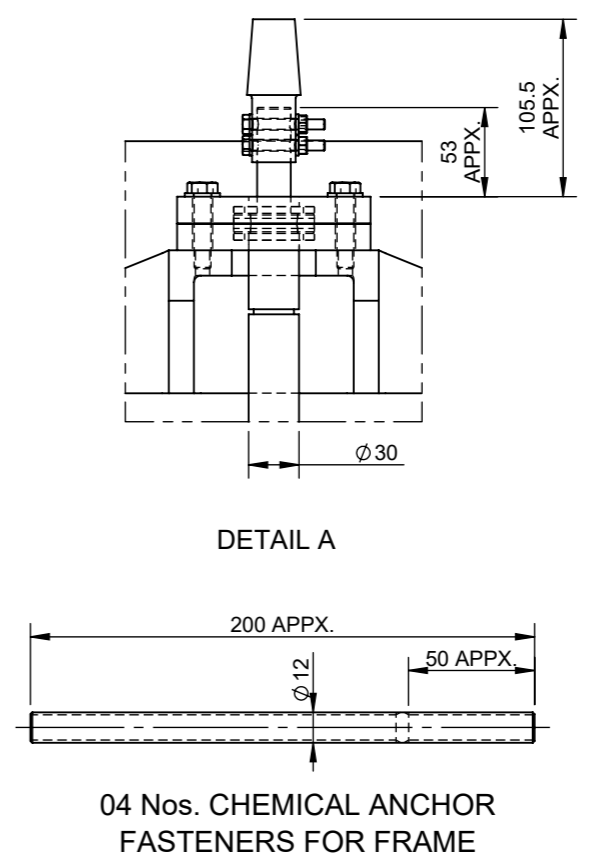

04 Nos. CHEMICAL ANCHOR FASTENERS FOR FRAME

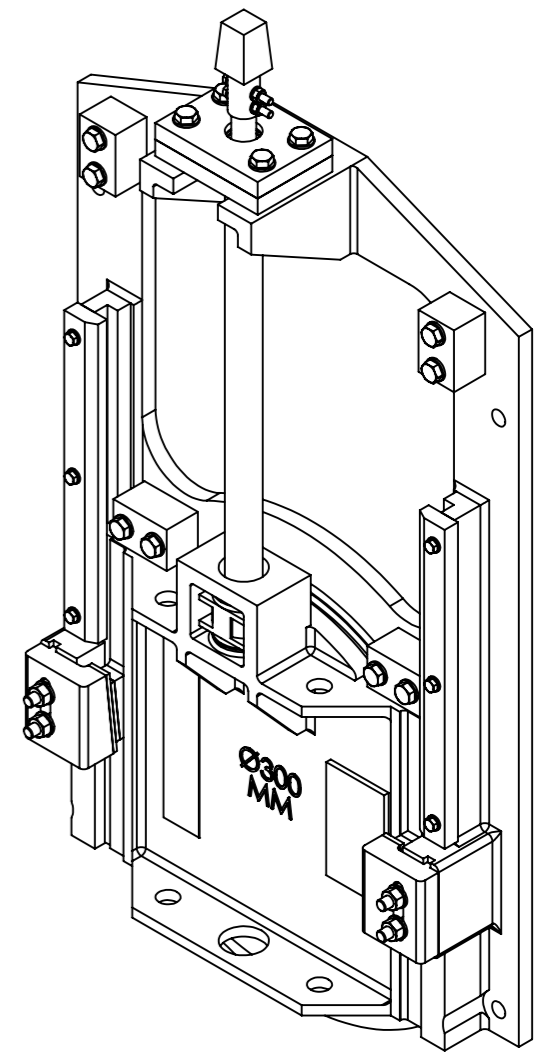

ISOMETRIC VIEW WITHOUT CIVIL

- NOTES :-
- ALLOWABLE DEVIATION FOR UNTOLERANCED DIMENSIONS OF CASTINGS TO BE AS PER ISO 8062-3.
  - ALLOWABLE DEVIATION FOR DIMENSIONS WITHOUT SPECIFIED TOLERANCES TO BE AS PER ISO:2768.
  - \* TRANSIT STOPS (PAINTED IN RED) SHOULD NOT BE REMOVED UNTIL THE GATE IS INSTALLED AND IS TO BE INITIALLY OPERATED.
  - ALL FASTENERS (NUTS, BOLTS & WASHERS) FOR GATE ASSEMBLY & BASE PLATE TO BE OF STAINLESS STEEL BS EN 10088-3 GR.1.4401 (TYPE 316) MATERIAL.
  - PAIN IS SUITABLE FOR DIRTY/SEWAGE WATER APPLICATION. BLACK EPOXY PAINT WITH BLACK SHADE (RAL 9005). TOTAL DRY FILM THICKNESS INCLUSIVE OF PRIMING TO BE 250 MICRONS.

- SEAT FACING TO BE FITTED ON PLAIN SURFACE OF SHUTTER AND FRAME.
- ADHESIVE CAPSULES/CHEMICAL CAPSULES AND CHEMICAL ANCHOR FASTENERS TO BE ARRANGED BY CLIENT.
- APPROX OUTER DIMENSIONS OF GATE ASSEMBLY IS 495(W) x 845 (H) x 130 (T) mm.
- APPROX WEIGHT SINGLE LARGEST COMPONENT IS 60 Kg. FOR SAFE HANDLING.
- # CHEMICAL ANCHOR FASTENERS HOLE LOCATION ON CIVIL WALL TO BE MARKED BY TAKING REFERENCE FROM GATE FRAME.

10	BASE PLATE	MILD STEEL
09	STEM BLOCK/THRUST NUT	PHOSPHORUS BRONZE BS EN 1982 GRADE CUSN11PB2-C (CC482K)
08	SEAT FACING	(R1)
07	STEM	STAINLESS STEEL BS EN 10088-3 GR.1.4401 (TYPE 316)
06	COVER RIB	CAST IRON BS EN 1561 GJL-250
05	SIDE WEDGING DEVICE (PHOSPHORUS BRONZE BS EN 12167 CUSN6-LINED)	
04	SHUTTER	HDPE
03	GATE FRAME	
02	OVER TRAVEL STOPPER	
* 01	TRANSIT STOPS	
SR. NO	DESCRIPTION	MATERIAL

WATERFRONT FLUID CONTROLS  
 MARITIME HOUSE (SUITE 8),  
 143 WOODVILLE ST, GLASGOW, G51 2RQ  
 WEB: www.waterfrontfc.co.uk  
 TEL: (44) 0141-445-3781  
 FAX: (44) 0141-445-5101

(R2)	05.12.23	Ø 300 MM WAS 300 x 300 MM	VST	DK
(R1)	21.9.23	SEAT FACING & THRUST NUT MOC CHANGED.	SV	AP
S.NO.	DATE	DESCRIPTION	REV.BY	APPROVAL

DRAWN BY: V.S.T.	PROJECT: STOCK ORDER	GENERAL TOLERANCES: MACHINING: ±0.2mm DIMS: <1000mm ±1.5mm DIMS: >1000mm ±2.0mm	FIRST ANGLE PROJECTION	DO NOT SCALE FROM THIS DRAWING
CHECKED BY: D.D.	CLIENT NAME: WATERFRONT FLUID CONTROLS LTD.	THIS DOCUMENT IS COPYRIGHT AND IS THE PROPERTY OF WATERFRONT FLUID CONTROLS. IT MUST NOT BE COPIED OR DISCLOSED TO A THIRD PARTY, INCLUDING MANUFACTURE OF THE PRODUCT SHOWN THEREIN, WITHOUT THE WRITTEN CONSENT OF THE COMPANY.		
APPROVED BY: D.K.	LOCATION: -----			
	QTY. - 10 NOS.	2009 WATERFRONT FLUID CONTROLS		

TITLE:- GENERAL ARRANGEMENT AND DETAILS FOR INSTALLATION SIZE:- Ø 300 WITH NON RISING SPINDLE SUITABLE FOR 6 M SEATING & 6 M UNSEATING WATER HEAD PROVIDED WITH CONVENTIONAL BOTTOM CLOSURE ARRANGEMENT AND HAVING MANUAL OPERATING ARRANGEMENT (GENERALLY MADE AS PER BS.7775)	DATE - 20.04.2023
MATERIAL: SEE MATERIAL NOTES	DRAWING NUMBER: GA-A-QTN-1210004832005
	REV NUMBER: R2
	SHEET NUMBER 1 OF 1