

**FRONT VIEW OF STAINLESS STEEL SLUICE GATE AFTER INSTALLATION**

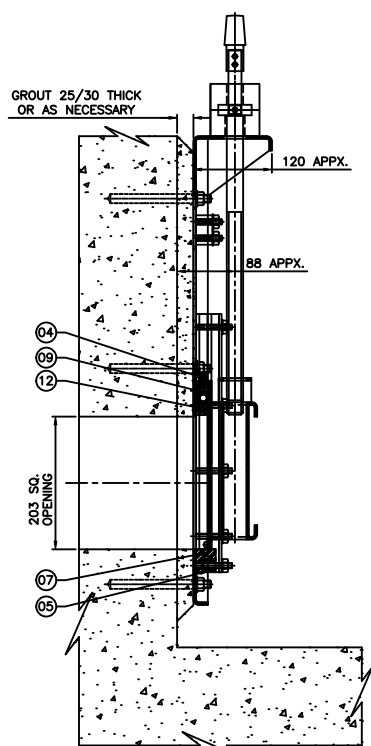

**SIDE VIEW WITH CUT SECTION OF WALL FOR COVENTIONAL BOTTOM CLOSURE GATE**

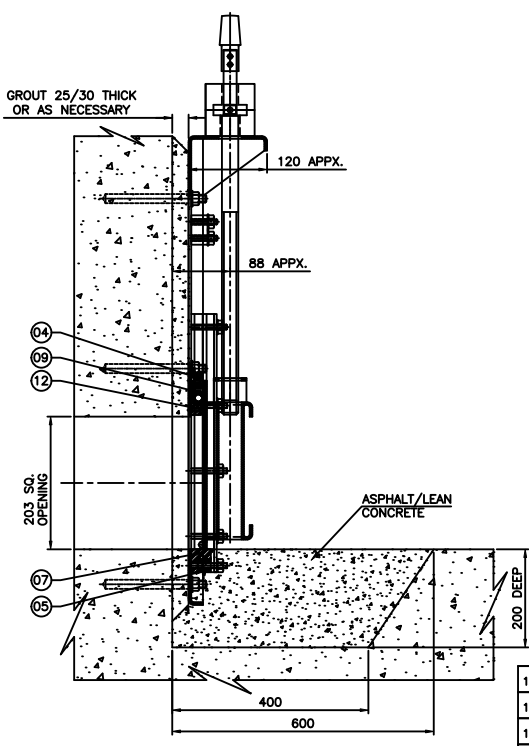

**SIDE VIEW WITH CUT SECTION OF WALL FOR FLUSH BOTTOM CLOSURE GATE**

16	UPPER PLATE	HDPE
15	LOWER PLATE	HDPE
14	END CAP FOR SPINDLE CONNECTION	ASTM A216 WCB
13	SIDE GUIDE	
12	TOP SEAL SUPPORT	HDPE
11	OVER TRAVEL STOP	
10	STEM	STAINLESS STEEL EN 1.4401 (316)
09	TOP SEAL	
08	SIDE SEAL	EPDM RUBBER
07	FLUSH BOTTOM RUBBER SEAL	
06	THRUST NUT	LEADED GUN METAL BS EN-1982 LG2
05	BOTTOM SEAL RETAINER	
04	TOP SEAL RETAINER	
03	SIDE SEAL RETAINER	STAINLESS STEEL EN 1.4401 (316)
02	SHUTTER	
01	FRAME	
Sr.	DESCRIPTION	MATERIAL

- NOTES :-  
 (1) ALLOWABLE DEVIATION FOR DIMENSIONS WITHOUT SPECIFIED TOLERANCES TO BE AS PER IS : 2768.  
 (2) ALL FASTENERS (NUTS, BOLTS & WASHERS) FOR GATE ASSEMBLY TO BE OF STAINLESS STEEL EN 1.4401 (316) MATERIAL.  
 (3) ALL STAINLESS STEEL FABRICATED PARTS TO BE BLAST CLEANED TO REMOVE SURFACE CONTAMINATION AND THEREAFTER PICKLED AND PASSIVATED

- (4) ADHESIVE CAPSULE/CHEMICAL CAPSULE & CHEMICAL ANCHOR FASTENERS TO BE ARRANGED BY CLIENT  
 (5) APPROX. OUTER DIMENSIONS OF GATE ASSLY IS 423 x 717 x 120mm.  
 (6) REFER DRG. NO. JE/SG/GEN/1490-R1 FOR SECTIONAL DETAILS.

WATERFRONT FLUID CONTROLS  
 WARRIEME HOUSE (SUITE 8)  
 143 WOODVILLE ST, GLASGOW, G51 2RQ  
 WEB: www.waterfrontfc.co.uk  
 TEL: (44) 0141-445-3781  
 FAX: (44) 0141-445-5101



REV	DATE	DESCRIPTION	REV. BY	CHD. BY
02	28.01.20	CHANGES AS PER MODIFIED END CAP.	GDC	S.A.
01	24.10.19	DIM. 204 & 84 ADDED.		S.A.

DRAWN BY: S.S.V.	PROJECT: ----
CHECKED BY: S.A.	CLIENT NAME: ----
APPROVED BY: D.K.	LOCATION: ----

GENERAL TOLERANCES:  
 MACHINING: ±0.2mm  
 DIMS: <1000mm ±1.5mm  
 DIMS: >1000mm ±2.0mm  
 FIRST ANGLE PROJECTION  
 DO NOT SCALE FROM THIS DRAWING  
 THIS DOCUMENT IS COPYRIGHT AND IS THE PROPERTY OF WATERFRONT FLUID CONTROLS. IT MUST NOT BE COPIED OR DISCLOSED TO A THIRD PARTY, INCLUDING MANUFACTURE OF THE PRODUCT SHOWN THEREIN, WITHOUT THE WRITTEN CONSENT OF THE COMPANY.  
 © 2009 WATERFRONT FLUID CONTROLS

TITLE:  
 DETAILS OF STAINLESS STEEL FACE WALL MOUNTING, UPWARD OPENING, SELF CONTAINED, NON-RISING SPINDLE, RESILIENT SEATED, SLUICE GATE SUITABLE FOR 6M SEATING AND UNSEATING WATER HEAD. GATE SIZE 203 SQ.  
 MATERIAL: SEE MATERIAL NOTES

DRAWING NUMBER:  
 JE/SG/GAC/FBF/10367-A  
 REV NUMBER: R2  
 SHEET NUMBER 1 OF 1