

ALL DIMENSIONS IN MM UNLESS OTHERWISE STATED

DO NOT SCALE - IF IN DOUBT ASK

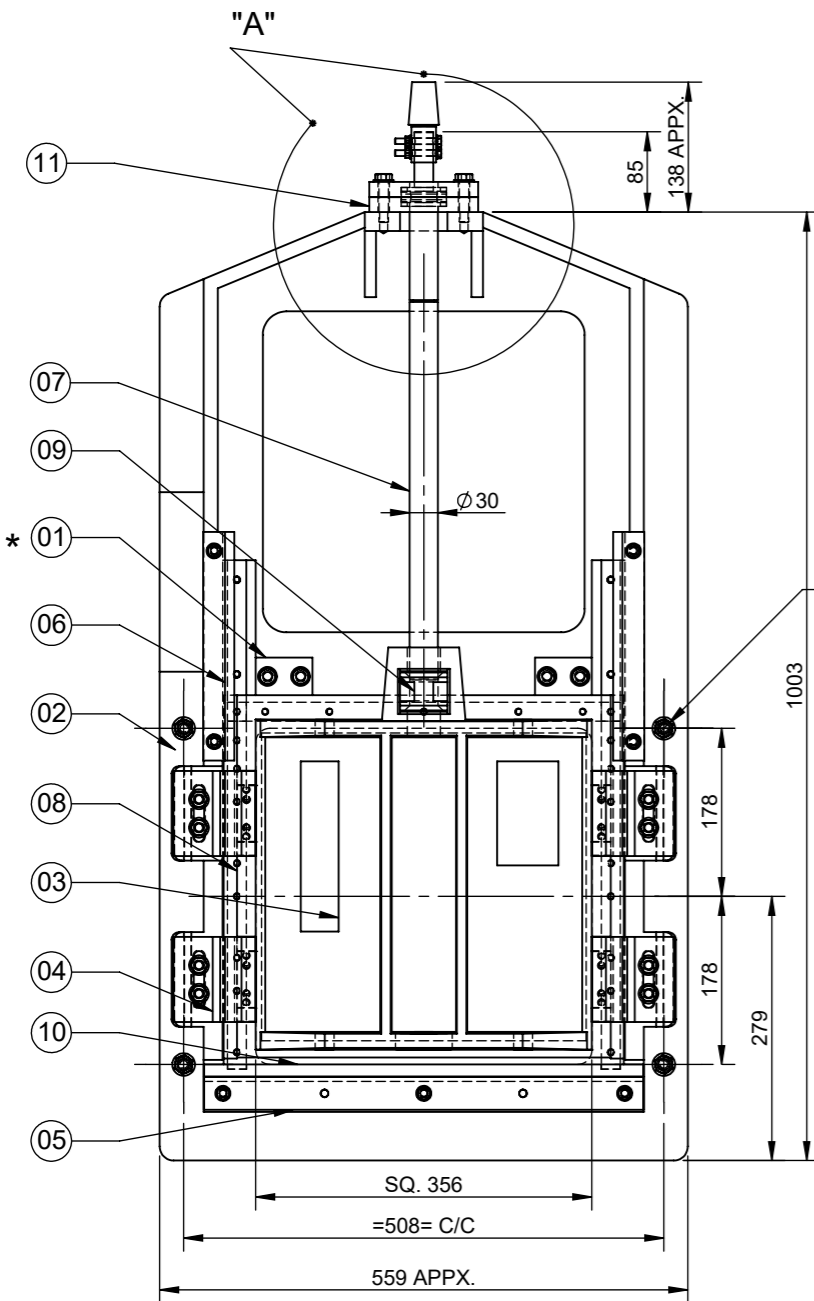

FRONT VIEW OF CAST IRON SLUICE GATE

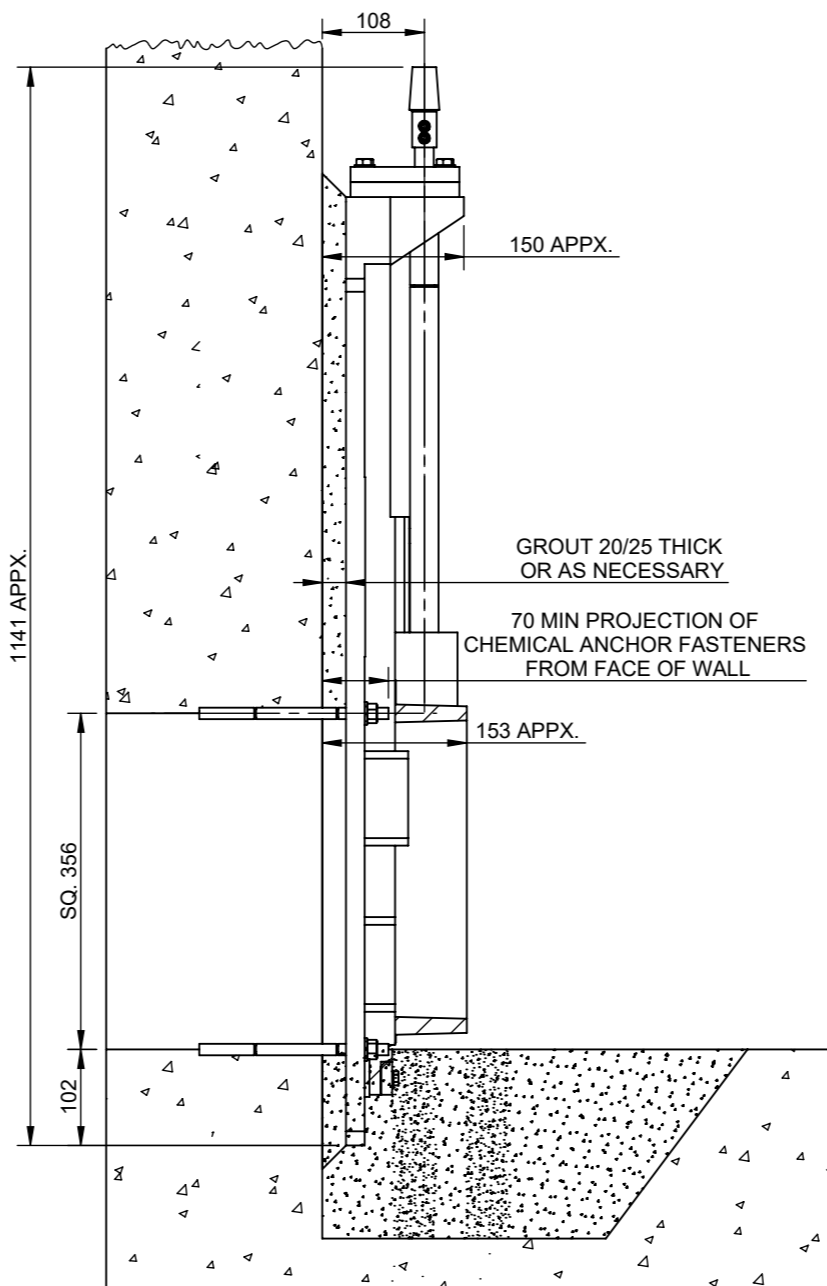

SIDE VIEW WITH CUT SECTION OF WALL

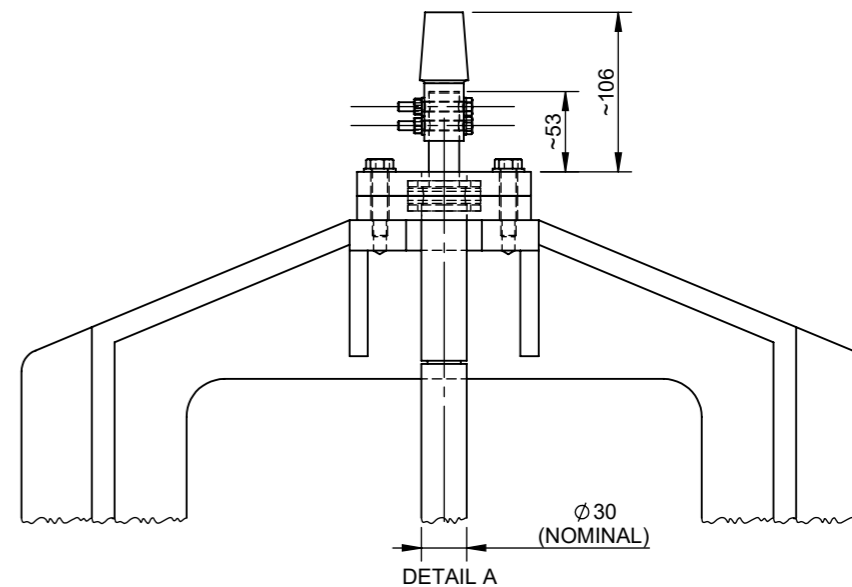

11	BASE PLATE	MILD STEEL
10	BOTTOM RUBBER SEAL	EPDM RUBBER
09	STEM BLOCK/THRUST NUT	GUNMETAL BSEN 1982 GR. LG2
08	SEAT FACING	GUNMETAL BSEN 1982 GR. LG2
07	STEM	STAINLESS STEEL BS EN 10088-3 GR.1.4401 (TYPE 316)
06	COVER RIB	CAST IRON BS EN 1561 GJL-250
05	BOTTOM SEAL SUPPORT BAR	
04	SIDE WEDGING DEVICE (LINED WITH GUNMETAL BSEN 1982 GR. LG2)	
03	SHUTTER	
02	GATE FRAME	
* 01	TRANSIT STOPS	HDPE
SR. NO	DESCRIPTION	MATERIAL

WATERFRONT FLUID CONTROLS
 MARITIME HOUSE (SUITE 8),
 143 WOODVILLE ST, GLASGOW, G51 2RQ
 WEB: www.waterfrontfc.co.uk
 TEL: (44) 0141-445-3781
 FAX: (44) 0141-445-5101



NOTES :-

- ALLOWABLE DEVIATION FOR UNTOLERANCED DIMENSIONS OF CASTINGS TO BE AS PER ISO 8062-3.
- ALLOWABLE DEVIATION FOR DIMENSIONS WITHOUT SPECIFIED TOLERANCES TO BE AS PER ISO:2768.
- * TRANSIT STOPS (PAINTED IN RED) SHOULD NOT BE REMOVED UNTIL THE GATE IS INSTALLED AND IS TO BE INITIALLY OPERATED.
- ALL FASTENERS (NUTS, BOLTS & WASHERS) FOR GATE ASSEMBLY, & BASE PLATE TO BE OF STAINLESS STEEL BS EN 10088-3 GR.1.4401 (TYPE 316) MATERIAL.
- PAINT IS SUITABLE FOR DIRTY/SEWAGE WATER APPLICATION. BLACK EPOXY PAINT WITH BLACK SHADE (RAL 9005). TOTAL DRY FILM THICKNESS INCLUSIVE OF PRIMING TO BE 250 MICRONS.

- SEAT FACING TO BE FITTED ON PLAIN SURFACE OF SHUTTER AND FRAME.
- ADHESIVE CAPSULES/CHEMICAL CAPSULES AND CHEMICAL ANCHOR FASTENERS TO BE ARRANGED BY CLIENT.
- PERMISSIBLE LEAKAGE LESS THAN FOR :-
 I. ON SEATING HEAD : 1.25 L/MIN/M OF SEAL PERIMETER.
 II. OFF SEATING HEAD : 2.5 L/MIN/M OF SEAL PERIMETER UP TO INCLUDING 6M WATER HEAD.
- APPX. WEIGHT OF GATE ASSEMBLY IS 104 KG. APPX.

S.NO.	DATE	DESCRIPTION	REV. BY	APPROVAL
1				
2				
3				
4				

DRAWN BY: MY	PROJECT:	GENERAL TOLERANCES: MACHINING: ±0.2mm DIMS: <1000mm ±1.5mm DIMS: >1000mm ±2.0mm	FIRST ANGLE PROJECTION	DO NOT SCALE FROM THIS DRAWING
CHECKED BY: SM	CLIENT NAME:	THIS DOCUMENT IS COPYRIGHT AND IS THE PROPERTY OF WATERFRONT FLUID CONTROLS. IT MUST NOT BE COPIED OR DISCLOSED TO A THIRD PARTY, INCLUDING MANUFACTURE OF THE PRODUCT SHOWN THEREIN, WITHOUT THE WRITTEN CONSENT OF THE COMPANY.		
APPROVED BY: DK	LOCATION:	2009 WATERFRONT FLUID CONTROLS		
	QTY. -			

TITLE:-
 GENERAL ARRANGEMENT AND DETAILS FOR INSTALLATION OF A-101 SIZE:-
 350X350 WITH NON RISING SPINDLE SUITABLE FOR 6 M SEATING & 3 M
 UNSEATING WATER HEAD PROVIDED WITH FLUSH BOTTOM CLOSURE
 ARRANGEMENT AND HAVING MANUAL OPERATING ARRANGEMENT
 (GENERALLY MADE AS PER BS:7775)
 MATERIAL: SEE MATERIAL NOTES

DATE - 23.02.2021
DRAWING NUMBER: GA-A-101-WSO-05
REV NUMBER: R0
SHEET NUMBER 1 OF 1