

FRONT VIEW

QTY 13 NOS, 18 THRU HOLES ON PCD. 1050 EQUI AS SHOWN FOR M16 FASTENERS

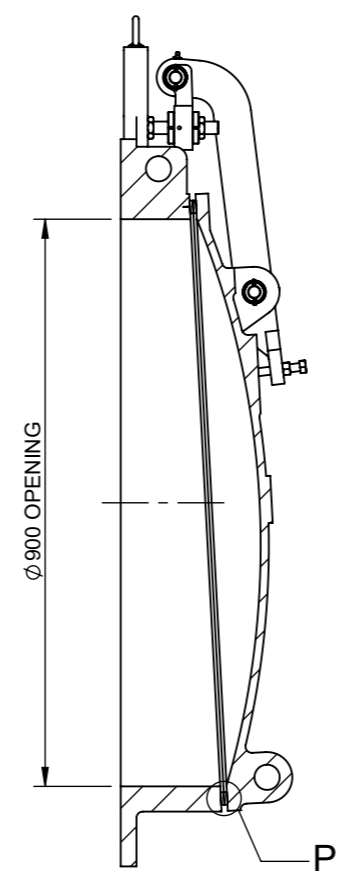

SECTION A-A

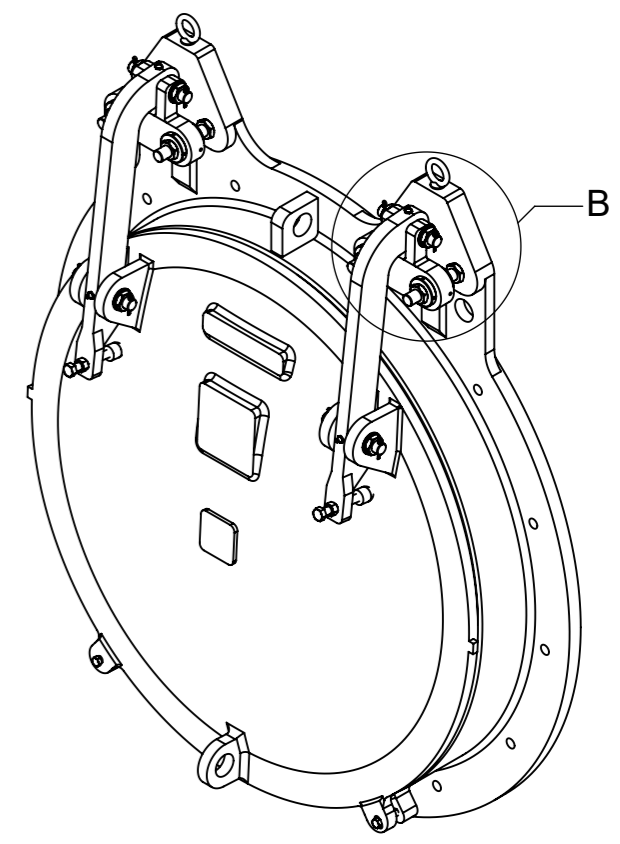

ISOMETRIC VIEW

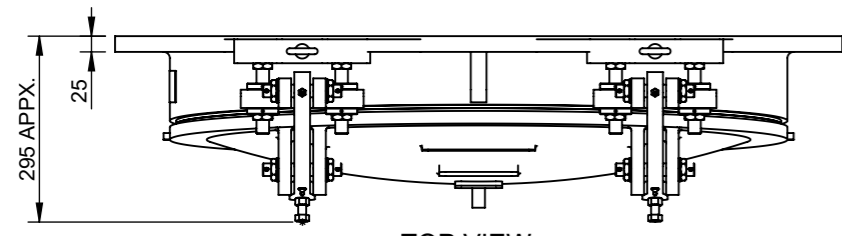

TOP VIEW

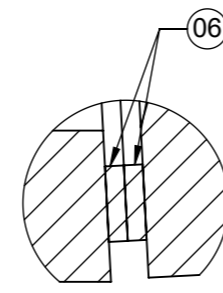

DETAIL P

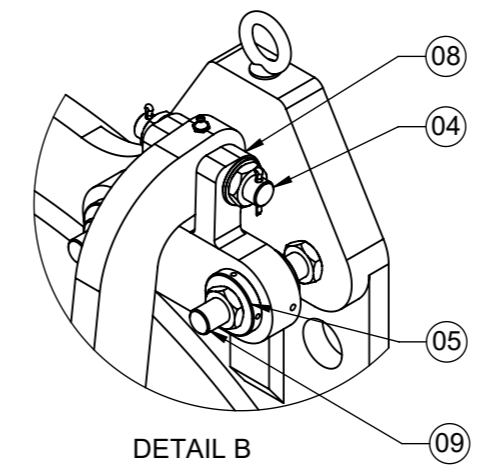

DETAIL B

NOTE :- PCD AS PER (PN16) EN 1092-2.

ALL DIMENSIONS ARE IN MILLIMETERS UNLESS OTHERWISE SPECIFIED.

- NOTES:**
1. ALLOWABLE DEVIATION FOR UNTOLERANCED DIMENSIONS OF CASTINGS TO BE AS PER ISO/TS 8062-3.
 2. ALLOWABLE DEVIATION FOR DIMENSIONS WITHOUT SPECIFIED TOLERANCES TO BE AS PER ISO:2768.
 3. ALL FASTENERS (NUTS,BOLTS & WASHERS) FOR GATE ASSEMBLY, CHEMNICAL ANCHOR FASTENERS FOR GATE FRAME TO BE OF STAINLESS STEEL ASTM A276 TYPE 316 MATERIAL.
 4. ADHESIVE CAPSULE/CHEMICAL CAPSULE FOR CHEMICAL ANCHOR FASTENERS TO BE ARRANGED BY CLIENT.
 5. APPROX. WEIGHT OF GATE ASSEMBLY IS 320 kgs.
 6. PAINT FOR FLAP GATE ASSEMBLY :- JOTUN TANKGUARD 412- EPOXY PAINT WITH BLACK SHADE TOTAL DFT 250 MICRONS.

SR.NO	DESCRIPTOPN	MATERIAL
09	HINGE STUD	STAINLESS STEEL ASTM A276 TYPE 431
08	HINGE PIN	S.S. ASTM A276 TYPE 316
07	BUSH	BRONZE ASTM B584 C86500
06	SEAT FACING	PHOSPHOR BRONZE BS EN 1982, GRADE CuSn11Pb2-C (CC482K)
05	DRIVE NUT	DUCTILE IRON EN1563 GJS-450-10
04	HINGE BLOCK	
03	HINGE ARM	CAST IRON BS EN 1561 GRADE 250
02	FLAP	
01	FRAME	

WATERFRONT FLUID CONTROLS
 MARITIME HOUSE (SUITE 8),
 143 WOODVILLE ST, GLASGOW, G51 2RQ
 WEB: www.waterfrontfc.co.uk
 TEL: (44) 0141-445-3781
 FAX: (44) 0141-445-5101

REV	DATE	DESCRIPTION	REV.BY	APPROVAL
1				

DRN BY:	PROJECT:- LAWYERS PUMPING STATION FLAP VALVES
CHKD BY:	CLIENT'S NAME :- WATERFRONT FLUID CONTROLS LTD.
A.P.	LOCATION :- - - - -
APPVD BY:	QTY. :-
D.K.	

GENERAL TOLERANCES:
 MACHINING: ±0.2mm
 DIMS: <1000mm ±1.5mm
 DIMS: >1000mm ±2.0mm

FIRST ANGLE PROJECTION

DO NOT SCALE FROM THIS DRAWING

THIS DOCUMENT IS COPYRIGHT AND IS THE PROPERTY OF WATERFRONT FLUID CONTROLS. IT MUST NOT BE COPIED OR DISCLOSED TO A THIRD PARTY, INCLUDING MANUFACTURE OF THE PRODUCT SHOWN THEREIN, WITHOUT THE WRITTEN CONSENT OF THE COMPANY.
 ©2009 WATERFRONT FLUID CONTROLS

TITLE:- GENERAL ARRANGEMENT & CIVIL BLOCKOUT DETAILS FOR A-604 SERIES GATE SIZE : Ø900 MM	DRAWING NO.: GA-A-WF-A-604-0017
MATERIAL: SEE MATERIAL NOTES	REV. NO.: R0
	SHEET NO. 1 OF 1