

FRONT VIEW

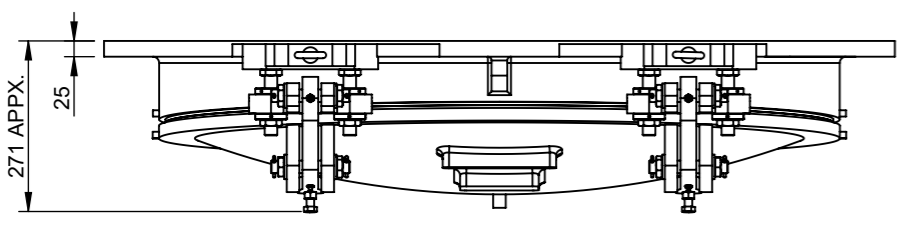

TOP VIEW

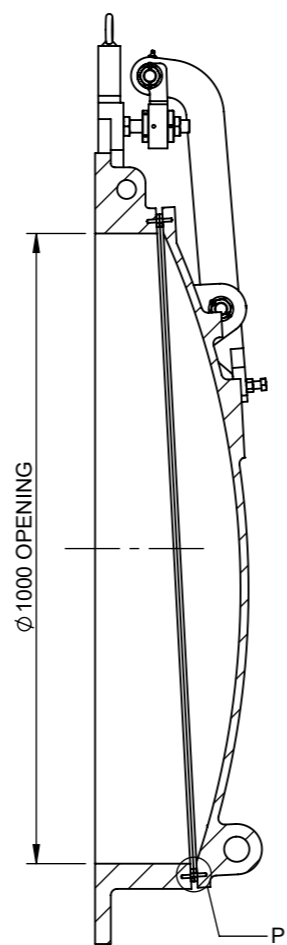

SECTION A-A

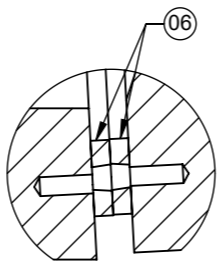

DETAIL P

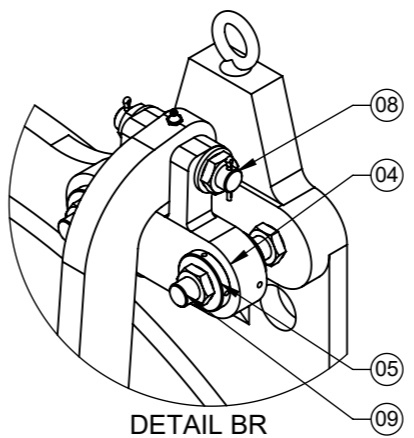

DETAIL BR

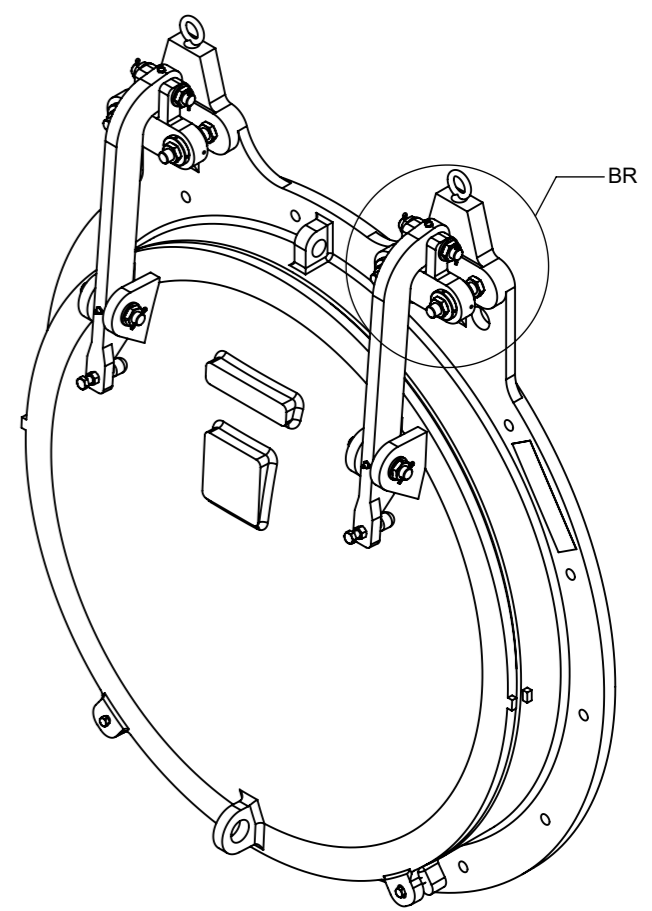

ISOMETRIC VIEW

QTY 14 NOS, 18 THRU HOLES ON PCD. 1170 EQUI AS SHOWN FOR M16 FASTENERS

NOTE :- PCD AS PER (PN16) EN 1092-2.

ALL DIMENSIONS ARE IN MILLIMETERS UNLESS OTHERWISE SPECIFIED.

- NOTES:**
- ALLOWABLE DEVIATION FOR UNTOLERANCED DIMENSIONS OF CASTINGS TO BE AS PER ISO/TS 8062-3.
 - ALLOWABLE DEVIATION FOR DIMENSIONS WITHOUT SPECIFIED TOLERANCES TO BE AS PER ISO:2768.
 - ALL FASTENERS (NUTS,BOLTS & WASHERS) FOR GATE ASSEMBLY, CHEMNICAL ANCHOR FASTENERS FOR GATE FRAME TO BE OF STAINLESS STEEL ASTM A276 TYPE 316 MATERIAL.
 - ADHESIVE CAPSULE/CHEMICAL CAPSULE FOR CHEMICAL ANCHOR FASTENERS TO BE ARRANGED BY CLIENT.
 - APPROX. WEIGHT OF GATE ASSEMBLY IS 350 kgs.
 - PAINT FOR FLAP GATE ASSEMBLY :- JOTUN TANKGUARD 412- EPOXY PAINT WITH BLACK SHADE TOTAL DFT 250 MICRONS.

09	HINGE STUD	STAINLESS STEEL ASTM A276 TYPE 431
08	HINGE PIN	S.S. ASTM A276 TYPE 316
07	BUSH	BRONZE ASTM B584 C86500
06	SEAT FACING	PHOSPHOR BRONZE BS EN 1982, GRADE CuSn11Pb2-C (CC482K)
05	DRIVE NUT	DUCTILE IRON EN1563 GJS-450-10
04	HINGE BLOCK	
03	HINGE ARM	
02	FLAP	CAST IRON BS EN 1561 GRADE 250
01	FRAME	
SR.NO	DESCRIPTOPN	MATERIAL

WATERFRONT FLUID CONTROLS
 MARITIME HOUSE (SUITE 8),
 143 WOODVILLE ST, GLASGOW, G51 2RQ
 WEB: www.waterfrontfc.co.uk
 TEL: (44) 0141-445-3781
 FAX: (44) 0141-445-5101



REV	DATE	DESCRIPTION	REV.BY	APPROVAL
1				

DRN BY:	PROJECT:-
D.T.	
CHKD BY:	CLIENT'S NAME :-
A.P.	
APPVD BY:	LOCATION :-
D.K.	QTY. :-

GENERAL TOLERANCES:
 MACHINING: ±0.2mm
 DIMS: <1000mm ±1.5mm
 DIMS: >1000mm ±2.0mm

FIRST ANGLE PROJECTION

DO NOT SCALE FROM THIS DRAWING

THIS DOCUMENT IS COPYRIGHT AND IS THE PROPERTY OF WATERFRONT FLUID CONTROLS. IT MUST NOT BE COPIED OR DISCLOSED TO A THIRD PARTY, INCLUDING MANUFACTURE OF THE PRODUCT SHOWN THEREIN, WITHOUT THE WRITTEN CONSENT OF THE COMPANY. ©2009 WATERFRONT FLUID CONTROLS

TITLE:-
GENERAL ARRANGEMENT & CIVIL BLOCKOUT DETAILS FOR A-604 SERIES GATE SIZE:Ø1000 MM

MATERIAL:
SEE MATERIAL NOTES

DRAWING NO.:
GA-A-WF-A-604-0019

REV. NO.: R0

SHEET NO.
1 OF 1