

ALL DIMENSIONS IN MM UNLESS OTHERWISE STATED

DO NOT SCALE - IF IN DOUBT ASK

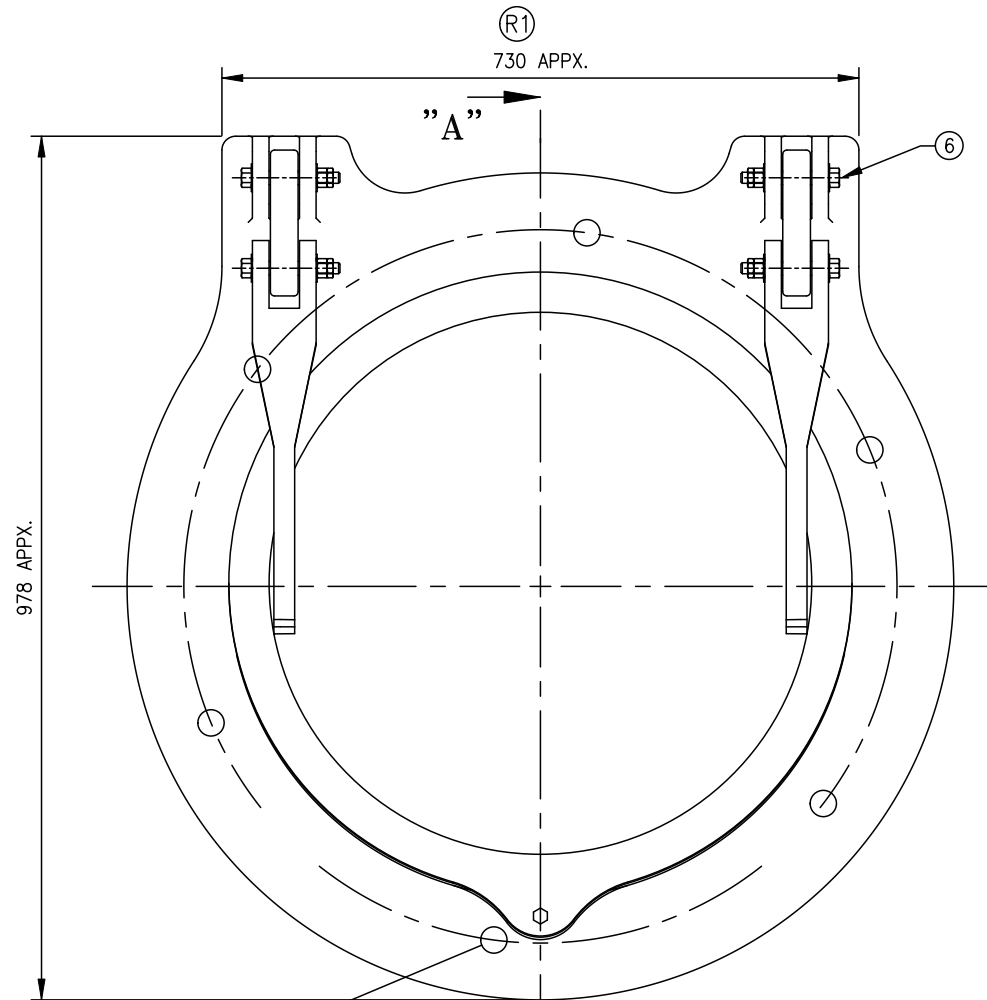

FRONT VIEW

6 NOS.  $\phi 19$  THRU HOLE ON  $\phi 840$  PCD. EQUI AS SHOWN FOR M16 FASTENERS

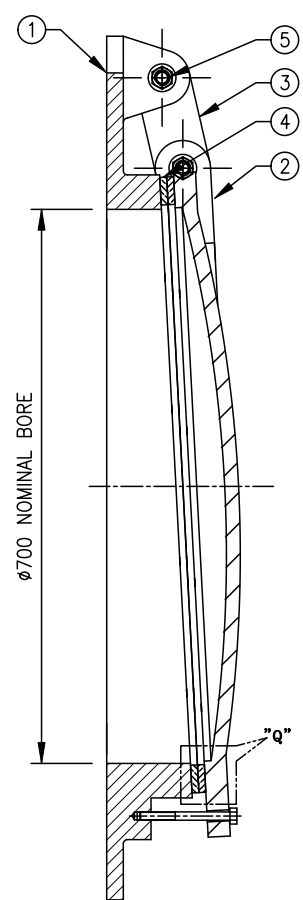

SECTION "A"-"A"

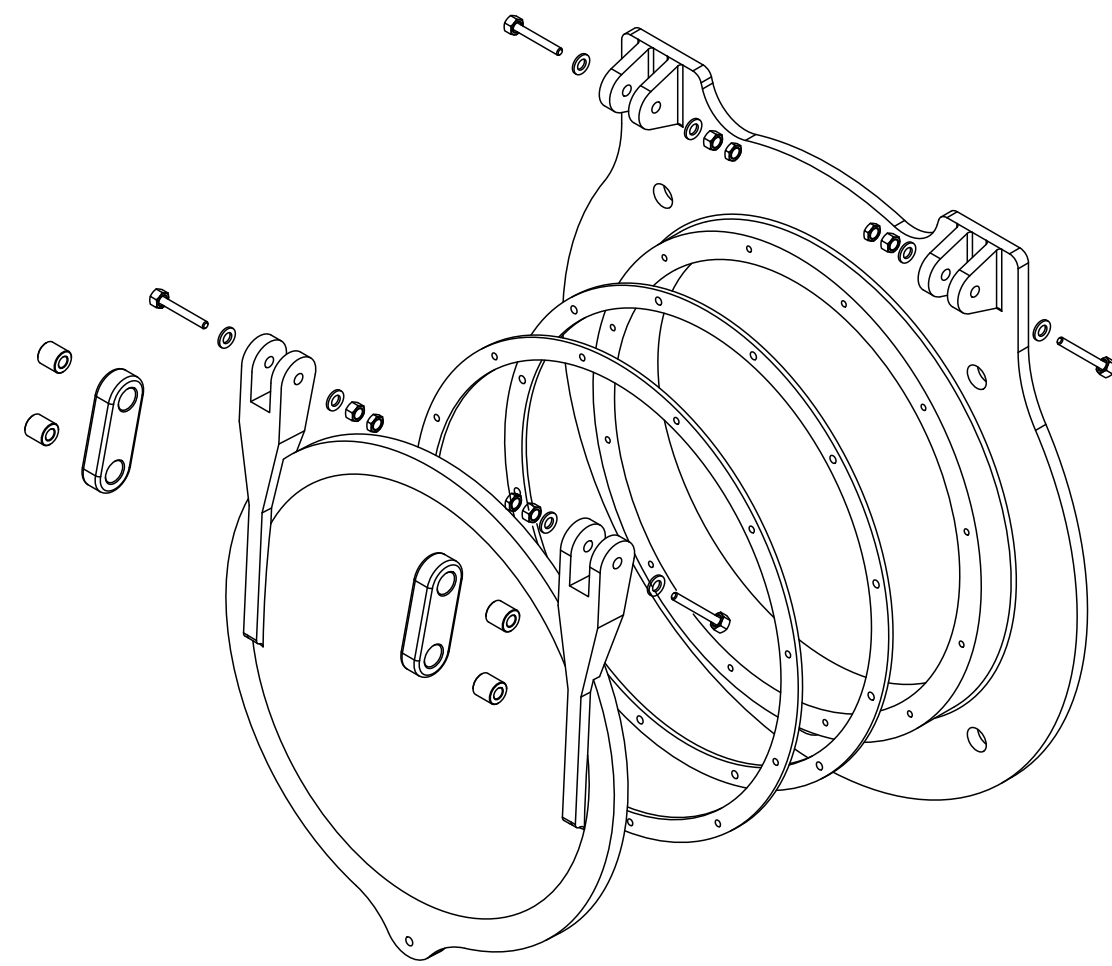

EXPLODED ISOMETRIC VIEW

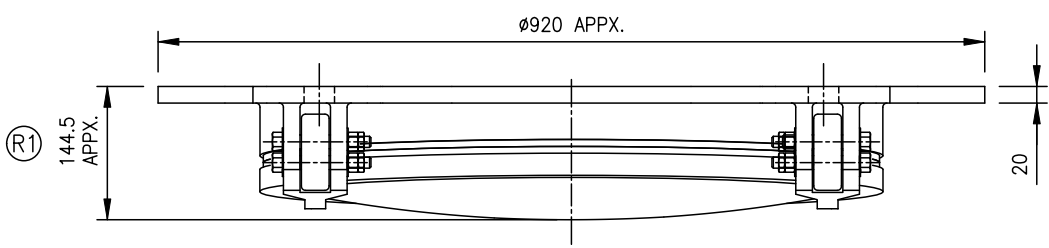

TOP VIEW

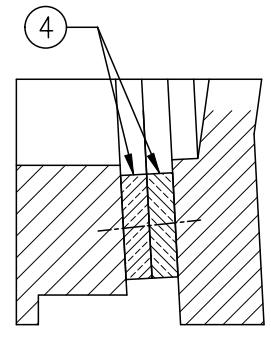

ENLARGE VIEW-"Q"

NOTE:- 1. PCD as per (PN16) EN 1092-2

- NOTES :-**
- ALLOWABLE DEVIATION FOR UNTOLERANCED DIMENSIONS OF CASTINGS TO BE AS PER ISO/TS 8062-2.
  - ALLOWABLE DEVIATION FOR DIMENSIONS WITHOUT SPECIFIED TOLERANCES TO BE AS PER ISO:2768.
  - ALL FASTENERS (NUTS,BOLTS & WASHERS) FOR GATE ASSEMBLY, CHEMICAL ANCHOR FASTENERS FOR GATE FRAME TO BE OF STAINLESS STEEL ASTM A276 TYPE 316 MATERIAL.
  - ADHESIVE CAPSULE/CHEMICAL CAPSULE FOR CHEMICAL ANCHOR FASTENERS TO BE ARRANGED BY CLIENT.
  - APPROX. WEIGHT OF GATE ASSEMBLY IS 155 kgs.
  - PAINT FOR FLAP GATE ASSEMBLY :- JOTUN TANKGUARD 412- EPOXY PAINT WITH BLACK SHADE TOTAL DFT 250 MICRONS.

Sr. Nos.	DESCRIPTION	MATERIAL
06	HINGE BUSH	UHMWPE ASTM D4020
05	HEX. BOLT	STAINLESS STEEL ASTM A276 TYPE 316
04	SEAT FACING	GUNMETAL BS EN 1982 GRADE LG2
03	LINK	STAINLESS STEEL ASTM A240 TYPE 316
02	SHUTTER/FLAP	CAST IRON BS EN 1561 GRADE 250
01	FRAME	

**WATERFRONT FLUID CONTROLS**  
 MARITIME HOUSE (SUITE 8),  
 143 WOODVILLE ST, GLASGOW, G51 2RQ  
 WEB: www.waterfrontfc.co.uk  
 TEL: (44) 0141-445-3781  
 FAX: (44) 0141-445-5101



REV	DATE	DESCRIPTION	APPROVAL
R1	24.03.2023	DIMENSION CHANGED.	D.K.

DRAWN BY: M.Y.	PROJECT: ----
CHECKED BY: S.M.	CLIENT NAME: ----
APPROVED BY: D.K.	LOCATION: ----
	QTY: ----

GENERAL TOLERANCES:  
 MACHINING:  $\pm 0.2\text{mm}$   
 DIMS:  $<1000\text{mm} \pm 1.5\text{mm}$   
 DIMS:  $>1000\text{mm} \pm 2.0\text{mm}$

FIRST ANGLE PROJECTION 

DO NOT SCALE FROM THIS DRAWING

THIS DOCUMENT IS COPYRIGHT AND IS THE PROPERTY OF WATERFRONT FLUID CONTROLS. IT MUST NOT BE COPIED OR DISCLOSED TO A THIRD PARTY, INCLUDING MANUFACTURE OF THE PRODUCT SHOWN THEREIN, WITHOUT THE WRITTEN CONSENT OF THE COMPANY.

© 2009 WATERFRONT FLUID CONTROLS

**TITLE:**  
 GENERAL ARRANGEMENT AND CIVIL BLOCKOUT  
 DETAILS FOR INSTALLATION OF FACE WALL  
 MOUNTED CAST IRON FLAP VALVE / GATE  
 (METAL SETAED) SIZE-  $\phi 700\text{mm}$

**MATERIAL:** SEE MATERIAL NOTES

**DRAWING NUMBER:**  
 JE/SG/GEN/1833-A

**REV NUMBER:** R1

**SHEET NUMBER** 1 OF 1