

ALL DIMENSIONS IN MM UNLESS OTHERWISE STATED

DO NOT SCALE - IF IN DOUBT ASK

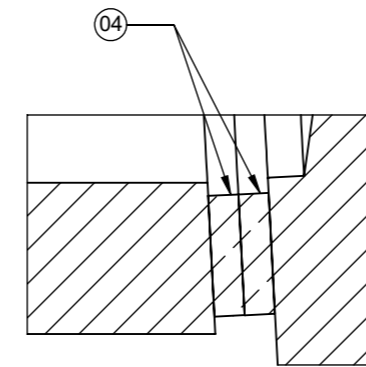
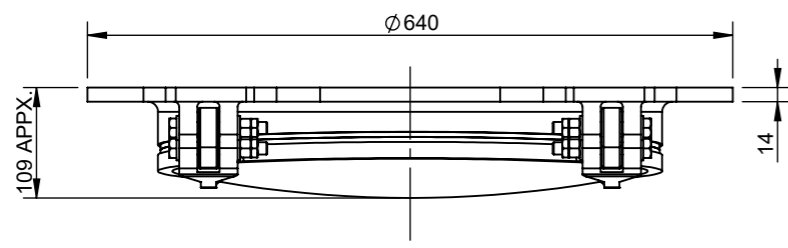
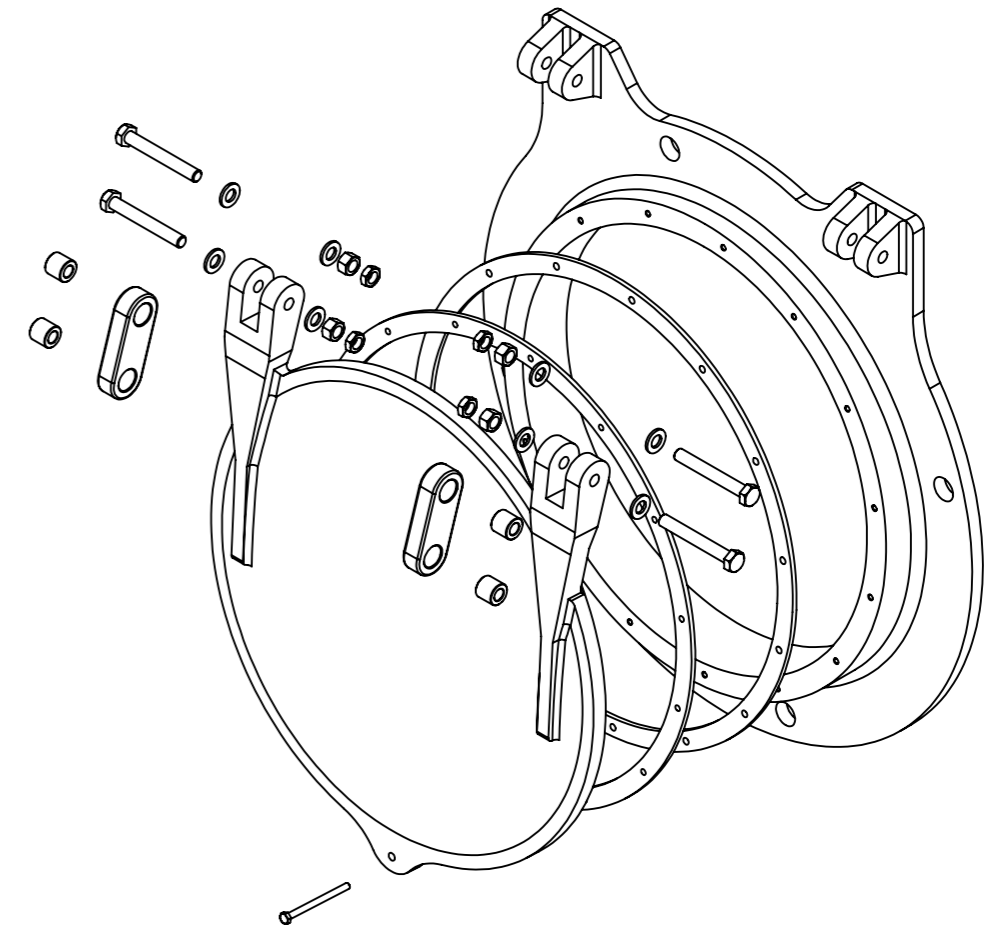
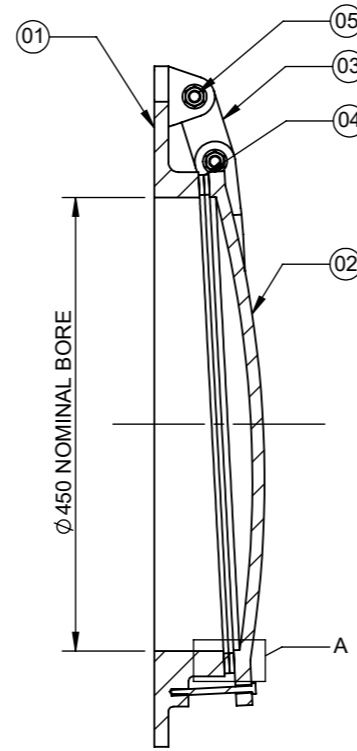
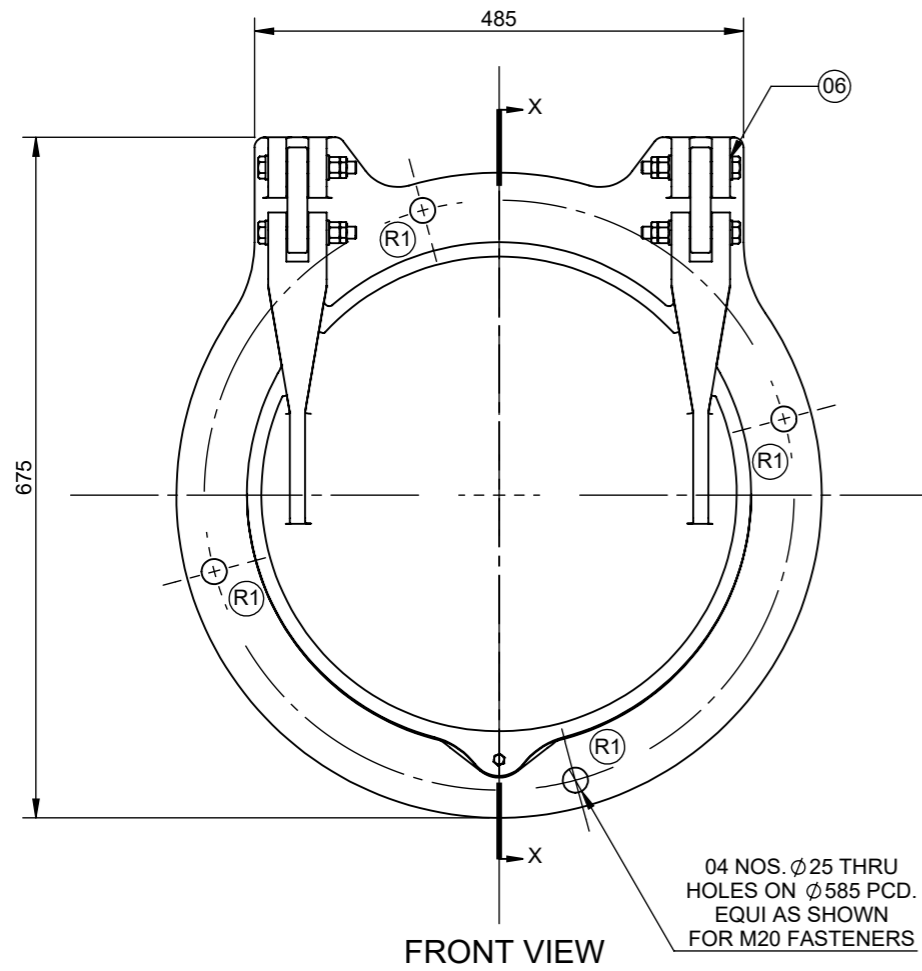

SR. NO	DESCRIPTION	MATERIAL
06	HINGE BUSH	UHMWPE ASTM D4020
05	HEX. BOLT	STAINLESS STEEL ASTM A276 TYPE 316
04	SEAT FACING	GUNMETAL BS EN 1982 GRADE LG2
03	LINK	STAINLESS STEEL ASTM A240 TYPE 316
02	SHUTTER / FLAP	CAST IRON BSEN 1561 GRADE 250
01	FRAME	

WATERFRONT FLUID CONTROLS  
 MARITIME HOUSE (SUITE 8),  
 143 WOODVILLE ST, GLASGOW, G51 2RQ  
 WEB: www.waterfrontfc.co.uk  
 TEL: (44) 0141-445-3781  
 FAX: (44) 0141-445-5101



NOTE:- 1. PCD AS PER (PN16) EN 1092-2.

NOTES :-

- ALLOWABLE DEVIATION FOR UNTOLERANCED DIMENSIONS OF CASTINGS TO BE AS PER ISO 8062-3.
- ALLOWABLE DEVIATION FOR DIMENSIONS WITHOUT SPECIFIED TOLERANCES TO BE AS PER ISO:2768.
- ALL FASTENERS (NUTS,BOLTS & WASHERS) FOR GATE ASSEMBLY, CHEMICAL ANCHOR FASTENERS FOR GATE FRAME TO BE OF STAINLESS STEEL ASTM A276 TYPE 316 MATERIAL.
- ADHESIVE CAPSULE/CHEMICAL CAPSULE FOR CHEMICAL ANCHOR FASTENERS TO BE ARRANGED BY CLIENT.
- APPROX. WEIGHT OF GATE ASSEMBLY IS 60 kgs.
- PAINT FOR FLAP GATE ASSEMBLY :- JOTUN TANKGUARD 412- EPOXY PAINT WITH BLACK SHADE TOTAL DFT 250 MICRONS.

DRAWN BY: VST		PROJECT:		GENERAL TOLERANCES: MACHINING: ±0.2mm DIMS: <1000mm ±1.5mm DIMS: >1000mm ±2.0mm		FIRST ANGLE PROJECTION		DO NOT SCALE FROM THIS DRAWING		TITLE:- GENERAL ARRANGEMENT AND CIVIL BLOCKOUT DETAILS FOR INSTALLATION OF FACE WALL MOUNTED CAST IRON FLAP VALVE / GATE (METAL SETAED) SIZE- Ø450mm		DATE - 16.01.2021	
CHECKED BY: SM		CLIENT NAME:		THIS DOCUMENT IS COPYRIGHT AND IS THE PROPERTY OF WATERFRONT FLUID CONTROLS. IT MUST NOT BE COPIED OR DISCLOSED TO A THIRD PARTY, INCLUDING MANUFACTURE OF THE PRODUCT SHOWN THEREIN, WITHOUT THE WRITTEN CONSENT OF THE COMPANY.		2009 WATERFRONT FLUID CONTROLS				DRAWING NUMBER: JE/SG/GEN/1926		REV NUMBER: R1	
APPROVED BY: DK		LOCATION:								MATERIAL: SEE MATERIAL NOTES		SHEET NUMBER 1 OF 1	
R1	21.11.2021	MOUNTING HOLE POSITION CHANGED		T.S.G	D.K								
S.NO.	DATE	DESCRIPTION		REV.BY	APPROVAL								