

ALL DIMENSIONS IN MM UNLESS OTHERWISE STATED

DO NOT SCALE - IF IN DOUBT ASK

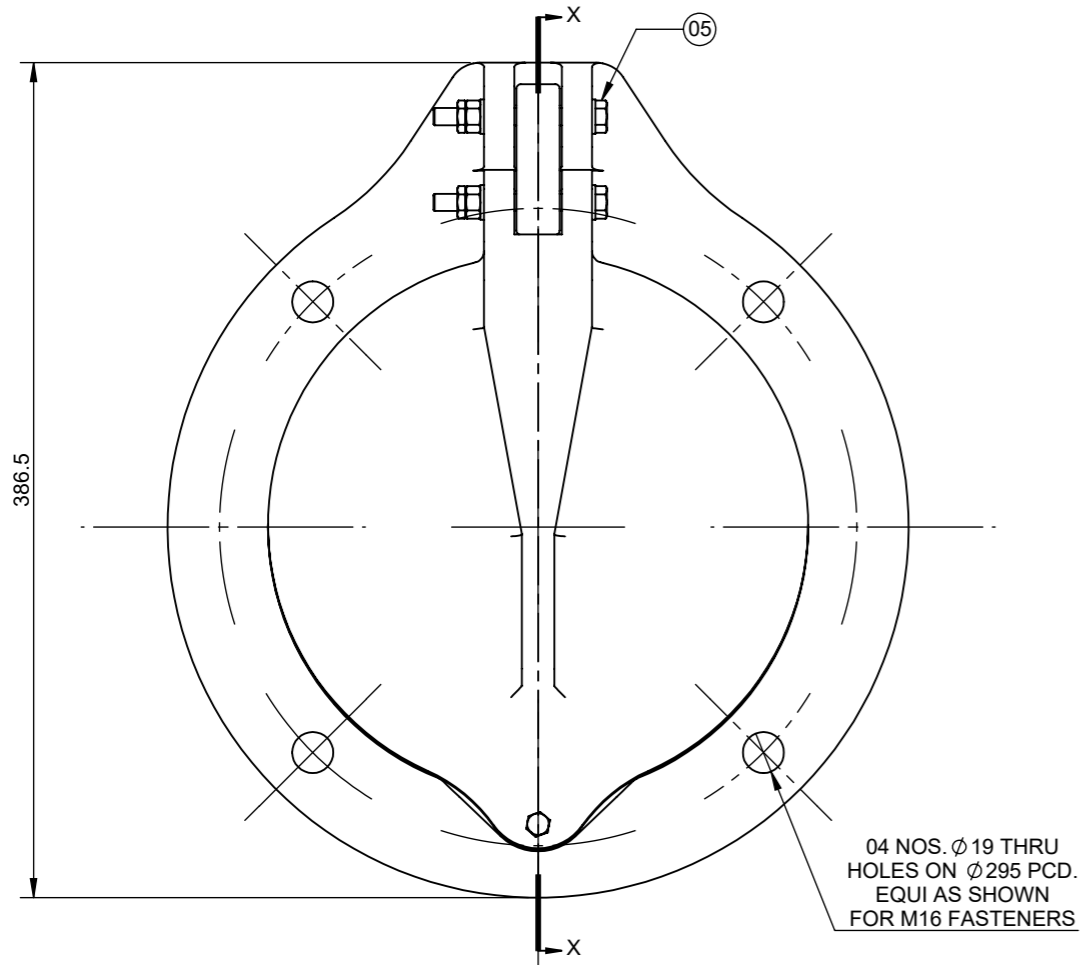

FRONT VIEW

04 NOS. ϕ 19 THRU HOLES ON ϕ 295 PCD. EQUI AS SHOWN FOR M16 FASTENERS

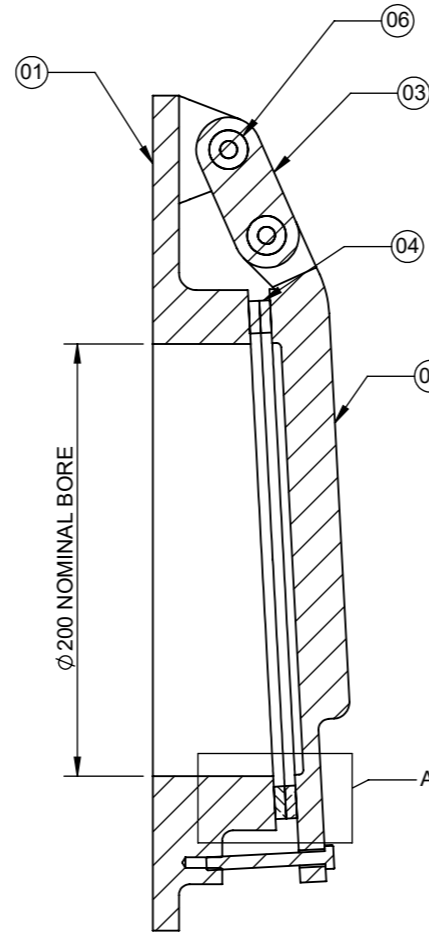

SECTION X-X

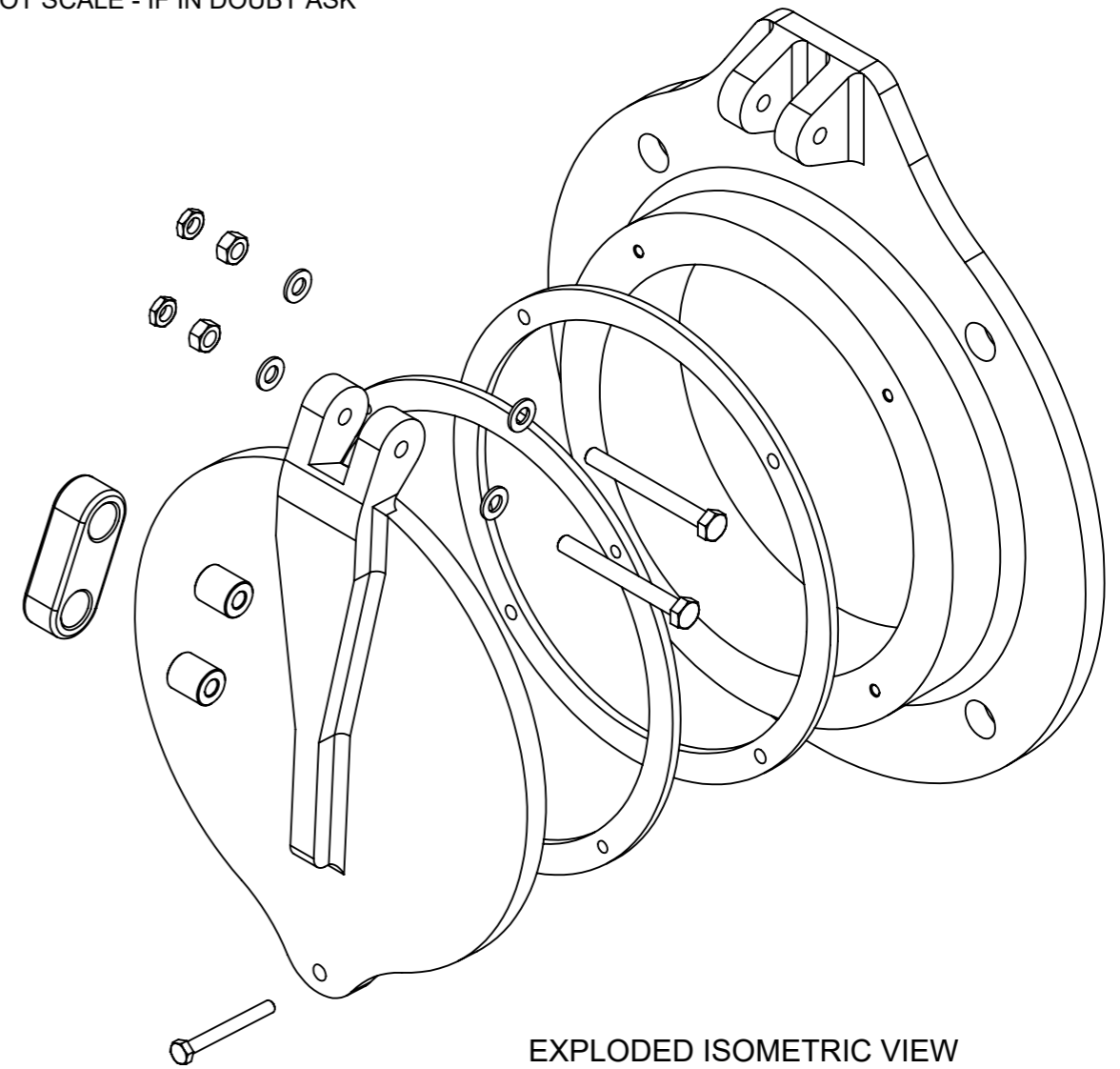

EXPLODED ISOMETRIC VIEW

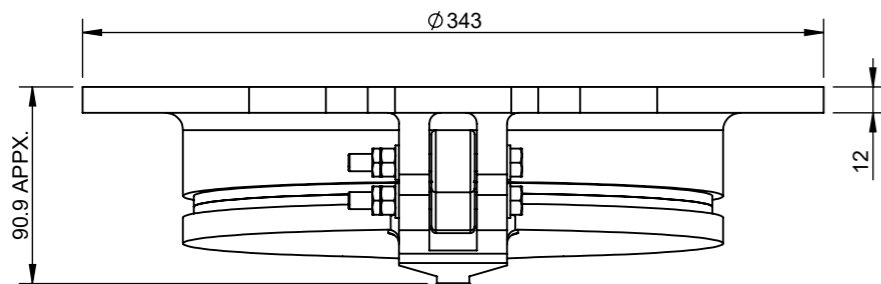

TOP VIEW

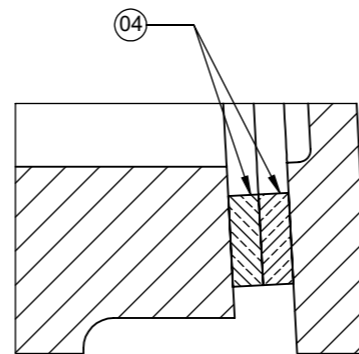

DETAIL A

NOTE:- 1. PCD AS PER (PN16) EN 1092-2.

NOTES :-

- ALLOWABLE DEVIATION FOR UNTOLERANCED DIMENSIONS OF CASTINGS TO BE AS PER ISO 8062-3.
- ALLOWABLE DEVIATION FOR DIMENSIONS WITHOUT SPECIFIED TOLERANCES TO BE AS PER ISO:2768.
- ALL FASTENERS (NUTS,BOLTS & WASHERS) FOR GATE ASSEMBLY, CHEMICAL ANCHOR FASTENERS FOR GATE FRAME TO BE OF STAINLESS STEEL ASTM A276 TYPE 316 MATERIAL.
- ADHESIVE CAPSULE/CHEMICAL CAPSULE FOR CHEMICAL ANCHOR FASTENERS TO BE ARRANGED BY CLIENT.
- APPROX. WEIGHT OF GATE ASSEMBLY IS 17 kgs.
- PAINT FOR FLAP GATE ASSEMBLY :- JOTUN TANKGUARD 412- EPOXY PAINT WITH BLACK SHADE TOTAL DFT 250 MICRONS.

SR. NO	DESCRIPTION	MATERIAL
06	HINGE BUSH	UHMWPE ASTM D4020
05	HEX. BOLT	STAINLESS STEEL ASTM A276 TYPE 316
04	SEAT FACING	GUNMETAL BS EN 1982 GRADE LG2
03	LINK	STAINLESS STEEL ASTM A240 TYPE 316
02	SHUTTER / FLAP	CAST IRON BSEN 1561 GRADE 250
01	FRAME	CAST IRON BSEN 1561 GRADE 250

WATERFRONT FLUID CONTROLS
 MARITIME HOUSE (SUITE 8),
 143 WOODVILLE ST, GLASGOW, G51 2RQ
 WEB: www.waterfrontfc.co.uk
 TEL: (44) 0141-445-3781
 FAX: (44) 0141-445-5101



S.NO.	DATE	DESCRIPTION	REV.BY	APPROVAL
1				

DRAWN BY: VST	PROJECT:
CHECKED BY: SM	CLIENT NAME:
APPROVED BY: DK	LOCATION:
	QTY. -

GENERAL TOLERANCES: MACHINING: \pm 0.2mm DIMS: <1000mm \pm 1.5mm DIMS: >1000mm \pm 2.0mm	FIRST ANGLE PROJECTION	DO NOT SCALE FROM THIS DRAWING
THIS DOCUMENT IS COPYRIGHT AND IS THE PROPERTY OF WATERFRONT FLUID CONTROLS. IT MUST NOT BE COPIED OR DISCLOSED TO A THIRD PARTY, INCLUDING MANUFACTURE OF THE PRODUCT SHOWN THEREIN, WITHOUT THE WRITTEN CONSENT OF THE COMPANY.		
2009 WATERFRONT FLUID CONTROLS		

TITLE:- GENERAL ARRANGEMENT AND CIVIL BLOCKOUT DETAILS FOR INSTALLATION OF FACE WALL MOUNTED CAST IRON FLAP VALVE / GATE (METAL SETAED) SIZE- ϕ 200mm	DATE - 30.01.2021 DRAWING NUMBER: JE/SG/GEN/1919 REV NUMBER: R0
MATERIAL: SEE MATERIAL NOTES	SHEET NUMBER 1 OF 1