

A

ALL DIMENSIONS IN MM UNLESS OTHERWISE STATED DO NOT SCALE - IF IN DOUBT ASK

A

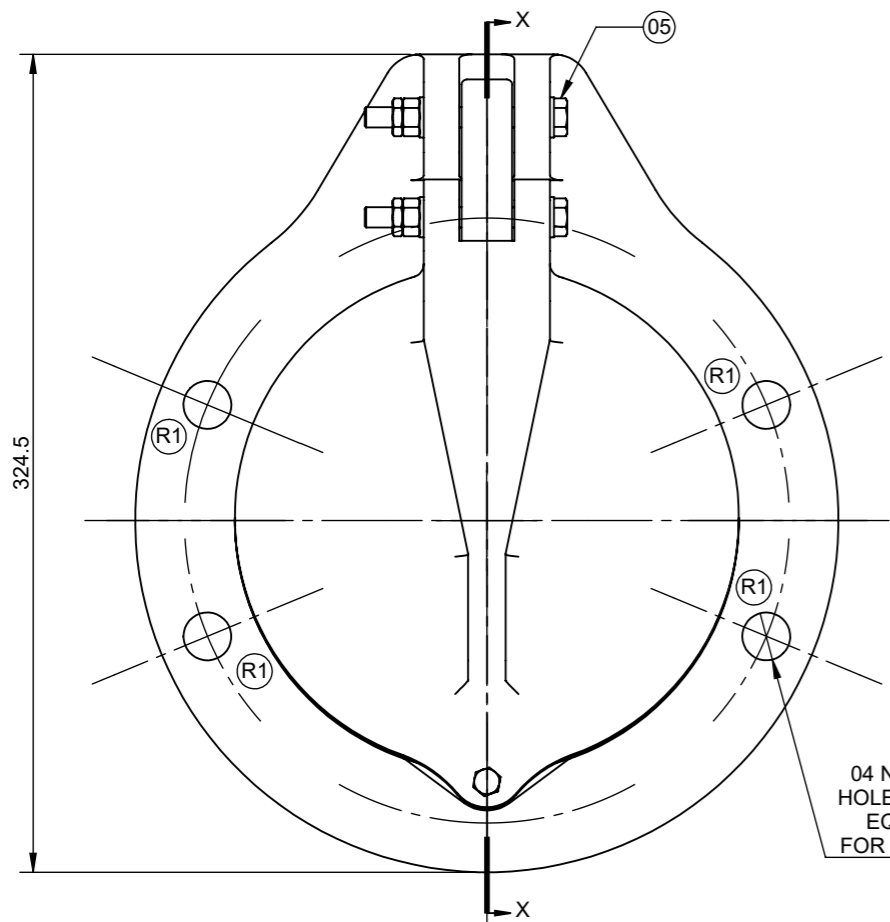

FRONT VIEW

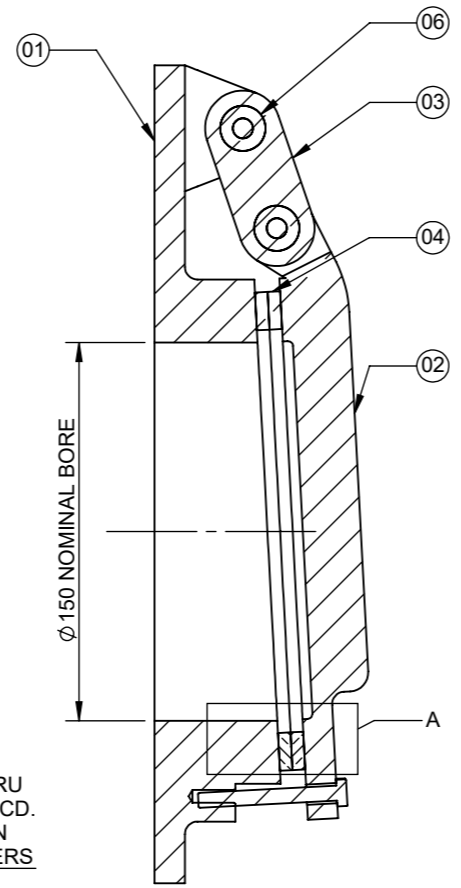

SECTION X-X

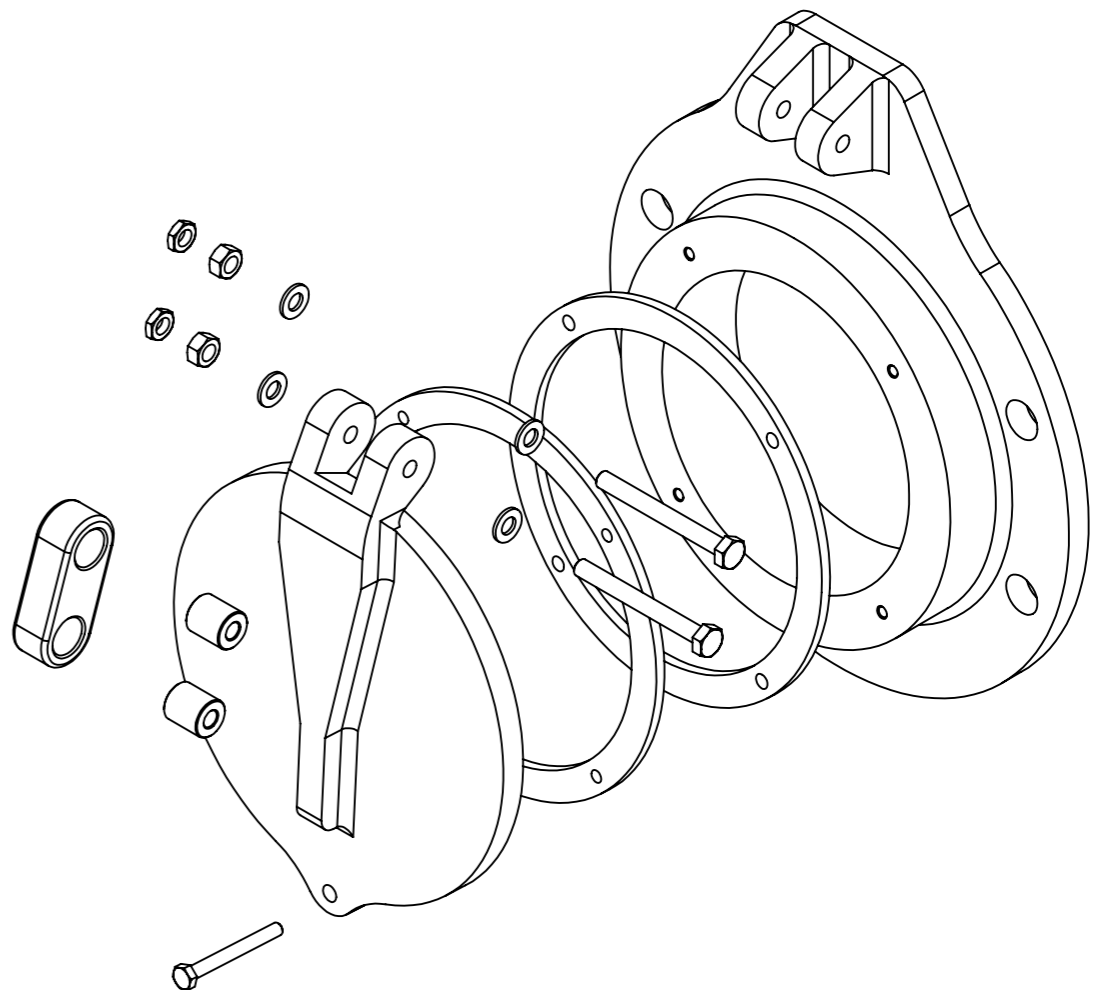

EXPLODED ISOMETRIC VIEW

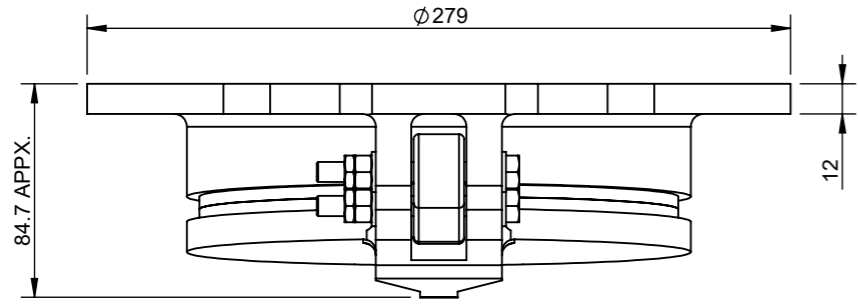

TOP VIEW

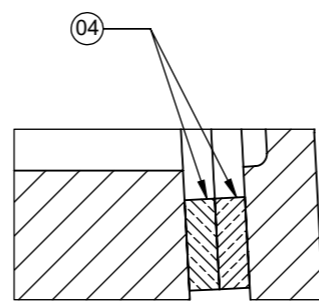

DETAIL A

04 NOS. Ø 19 THRU HOLES ON Ø 240 PCD. EQUI AS SHOWN FOR M16 FASTENERS

NOTE:- 1. PCD AS PER (PN16) EN 1092-2.

- NOTES :-
1. ALLOWABLE DEVIATION FOR UNTOLERANCED DIMENSIONS OF CASTINGS TO BE AS PER ISO 8062-3.
  2. ALLOWABLE DEVIATION FOR DIMENSIONS WITHOUT SPECIFIED TOLERANCES TO BE AS PER ISO:2768.
  3. ALL FASTENERS (NUTS,BOLTS & WASHERS) FOR GATE ASSEMBLY, CHEMICAL ANCHOR FASTENERS FOR GATE FRAME TO BE OF STAINLESS STEEL ASTM A276 TYPE 316 MATERIAL.
  4. ADHESIVE CAPSULE/CHEMICAL CAPSULE FOR CHEMICAL ANCHOR FASTENERS TO BE ARRANGED BY CLIENT.
  5. APPROX. WEIGHT OF GATE ASSEMBLY IS 12.5 kgs.
  6. PAINT FOR FLAP GATE ASSEMBLY :- JOTUN TANKGUARD 412- EPOXY PAINT WITH BLACK SHADE TOTAL DFT 250 MICRONS.

SR. NO	DESCRIPTION	MATERIAL
06	HINGE BUSH	UHMWPE ASTM D4020
05	HEX. BOLT	STAINLESS STEEL ASTM A276 TYPE 316
04	SEAT FACING	GUNMETAL BS EN 1982 GRADE LG2
03	LINK	STAINLESS STEEL ASTM A240 TYPE 316
02	SHUTTER / FLAP	CAST IRON BSEN 1561 GRADE 250
01	FRAME	CAST IRON BSEN 1561 GRADE 250

WATERFRONT FLUID CONTROLS  
 MARITIME HOUSE (SUITE 8),  
 143 WOODVILLE ST, GLASGOW, G51 2RQ  
 WEB: www.waterfrontfc.co.uk  
 TEL: (44) 0141-445-3781  
 FAX: (44) 0141-445-5101



S.NO.	DATE	DESCRIPTION	REV.BY	APPROVAL
R1	25.11.2021	MOUNTING HOLE POSITION CHANGED	T.S.G	D.K

DRAWN BY: VST	PROJECT:	GENERAL TOLERANCES: MACHINING: ±0.2mm DIMS: <1000mm ±1.5mm DIMS: >1000mm ±2.0mm	FIRST ANGLE PROJECTION	DO NOT SCALE FROM THIS DRAWING
CHECKED BY: SM	CLIENT NAME:	THIS DOCUMENT IS COPYRIGHT AND IS THE PROPERTY OF WATERFRONT FLUID CONTROLS. IT MUST NOT BE COPIED OR DISCLOSED TO A THIRD PARTY, INCLUDING MANUFACTURE OF THE PRODUCT SHOWN THEREIN, WITHOUT THE WRITTEN CONSENT OF THE COMPANY.		
APPROVED BY: DK	LOCATION:	2009 WATERFRONT FLUID CONTROLS		
QTY. -				

TITLE:- GENERAL ARRANGEMENT AND CIVIL BLOCKOUT DETAILS FOR INSTALLATION OF FACE WALL MOUNTED CAST IRON FLAP VALVE / GATE (METAL SETAED) SIZE- Ø150mm	DATE - 01.02.2021 DRAWING NUMBER: JE/SG/GEN/1918 REV NUMBER: R1
MATERIAL: SEE MATERIAL NOTES	SHEET NUMBER 1 OF 1

A2